

ETC Installation Guide

EchoTouch Controller Mk2

Overview

EchoTouch is an all-in-one flush or surface-mounted graphic touchscreen controller that provides control of Echo Zones and connectivity with other Echo control and output products.

EchoTouch also provides local control of a full universe of DMX outputs, and sACN or Art-Net outputs. Echo is compatible with all RDM enabled devices.

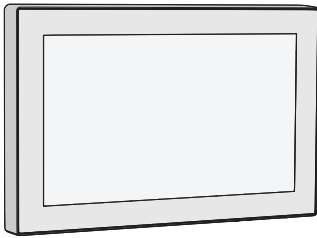

Features:

- 64 Presets shared across the Echo control system
- 80 Channels of patchable control
- 4 internal Sequences (DMX, sACN, and Art-Net only)

Prepare for Installation

EchoTouch ships with the touchscreen, a mounting collar, and an installation termination kit. It is designed for installation into a standard three-gang deep flush-mount back box (sold separately) or a surface-mount back box (ETC part number 7186A1116-4).

The following installation parts and supplies are included:

- (1) five-position screw terminal connector - J3228-F
- (1) three-position screw terminal connector - J30193-F
- (1) three-position Cat5 insulation displacement connector - J30187-F
- (3) cable ties for DMX out cable preparation
- heat shrink - various sizes and lengths for DMX out cable preparation
- receptacle spacers
- mounting screws – (4) 6-32 x 0.75" and (4) 6-32 x 1.75"



Corporate Headquarters Middleton, WI, USA +1 608 831 4116
London, UK +44 (0)20 8896 1000 **Holzkirchen, DE** +49 (80 24) 47 00-0
Rome, IT +39 (06) 32 111 683 **Hong Kong** +852 2799 1220 **Paris, FR** +33 1 4243 3535
Web etcconnect.com **Support** support.etcconnect.com

Contact etcconnect.com/contact ETC © 2020 Electronic Theatre Controls, Inc.
Product information and specifications subject to change. ETC intends this document to be provided in its entirety. Trademark and patent info: etcconnect.com/ip
7186M2193 Rev C Released 2020-10

ETC Installation Guide

EchoTouch

Specifications

Ambient Environment

For indoor use only. 0°C - 40°C (32°F - 104°F) operating temperatures in 0-95% non-condensing humidity.

Compliance

- UL and cUL listed
- Conforms to EN 62368-1 (Part 1 Safety Requirements)
- CE listed
- FCC compliant

Electrical and Auxiliary Wiring Specification

EchoTouch is powered by either Auxiliary power or by Power over Ethernet (PoE 802.3af).



Note: *This product is intended for use with a Listed power source (LPS) marked "Class 2", or LPS rated 24 VDC, minimum 0.59 A, or 48 VDC (PoE), minimum 0.234 A.*

- **Auxiliary Power** - 24 VDC auxiliary power requires two 1.5 mm² (16 AWG) wires and terminates to the provided removable pluggable connector. The unit draws 400 mA (typical) during normal operation, with a maximum of 750 mA draw.
 - **Power over Ethernet** - PoE requires Category 5 cable or approved equal with an RJ45 (Category 5 compliant) connector terminated to T568B scheme. EchoTouch includes an RJ45 receptacle on the back panel for connection of PoE. As required, separately order an Ethernet Cat5 Termination Kit from ETC (order part number 4101A2003) which includes building wire termination supplies, instructions, and an Ethernet patch cable.
-



Note: *PoE and all interconnected information technology equipment (ITE) are intended for intra-building connection.*



Note: *When both 24 VDC auxiliary power and PoE are connected to EchoTouch, auxiliary power will be the preferred input.*

- **ESD Ground** required when the wiring has not been installed in grounded metal conduit. Requires one 2.5 mm² (14 AWG) building wire terminated to the provided removable pluggable connector.
-

ETC Installation Guide

EchoTouch

Control Wiring Specification

EchoTouch can be used with the Echo control system using EchoConnect, and provides 512 channels of DMX out, and 512 channels of sACN out to a networked system.



Note: *Know the intent of use for this controller in your installation. All terminations may not be required.*

Control Type-Preferred Wire	Notes
EchoConnect using Belden 8471 (or equivalent)	EchoConnect is a bidirectional protocol that uses one pair of wires (data + and data -). The total combined length of an EchoConnect wire run (using recommended Belden 8471) may not exceed 500 m (1,640 ft). When using Category 5 (or equivalent) cable on the EchoConnect communication bus, please note that not all topologies are supported. Careful planning is required to ensure the proper termination and the wire is pulled appropriately. Refer to the installation guide that is provided with the Cat5 Station Termination Kit (7186A1207) for information to terminate Category 5 wiring.
DMX out using Belden 9729 (or equivalent)	DMX is installed in a daisy chain topology and includes one pair of wires (data + and data -, plus common). The maximum recommended length of the wire run is 487 m (1,600 ft). Cable preparation is required before termination.
DMX out using Category 5 (or better)	DMX can optionally use Category 5 cable following the ANSI standard E1.27-2 (data+ and data-, plus common), terminated to T-568B scheme.
sACN out using Ethernet network	sACN control is over a network using an Ethernet connection to a gateway or network switch. As required, order an Ethernet Cat5 Termination Kit (ETC part number 4101A2003) which includes building wire termination supplies, instructions, and an Ethernet patch cable.



Note: *Wiring should only be installed and terminated by a qualified technician and should follow standard wiring installation practices. Leave approximately 20 cm (8 in) of wiring in the back box for connection and to allow slack for future service needs.*

ETC Installation Guide

EchoTouch

Configuration

This document guides you through the installation of the EchoTouch controller. For more detailed information about graphic configuration options available, see the integrated help system.

Installation



Note: *The installation must follow local codes and standard practices.*

Install the Mounting Collar

EchoTouch installs to a 3-gang deep back box, to a specialized ETC surface-mount back box, or to an Echo Rack-mount kit.

- Listed 3-gang deep back box (by others) - in accordance with NEC and local electrical codes.
- EchoTouch surface-mount back box, sold separately (order part number 7186A1116-4) or the locking cover surface-mount back box, sold separately (order part number 7186A2219). If using a surface-mount back box by others, it must be in accordance with NEC and local electrical codes. See the Locking Cover installation instructions before proceeding with the installation.
- EchoTouch Rack-mount kit available from ETC (order part number 7186A1117). See the Rack-mount kit installation instructions before proceeding with the installation.

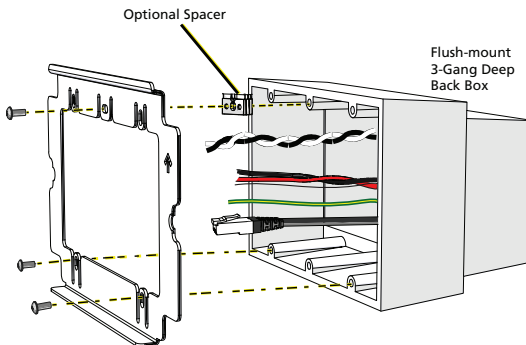

ETC Installation Guide

EchoTouch

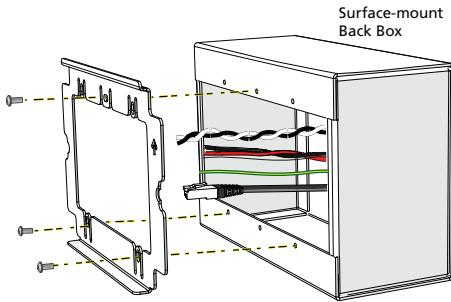

1. Install the back box.

- Flush-mount back box - when preparing the installation location, carefully cut the hole in the wall surface material and ensure there are no gaps around the box.
- Surface-mount back box - installation hardware is not provided. The installation location must support up to 2.3 kg (5 lbs), which includes the EchoTouch, surface-mount back box, and wiring. Align the back box to the installation location and secure in place using four 6 mm (1/4 in) mounting bolts or screws (not provided).

2. Run all power and control wires to the installation location. See [Electrical and Auxiliary Wiring Specification on page 2](#) and [Control Wiring Specification on page 3](#) for details.



Note: *The installation must follow local codes and standard practices. Use conduit if required.*

3. Install the mounting collar to the back box.

- a. Align the mounting collar to the back box with the arrows directed up.
- b. Use three mounting screws (provided) to loosely install the mounting collar to the back box. Install two screws on the bottom and one screw installed on the center top mounting slot (as pictured on the previous page) for optimal leveling adjustment.
- c. Adjust the mounting collar in the slotted mounting holes for a flush and level installation, then tighten the mounting screws.

ETC Installation Guide

EchoTouch



Note: For flush-mount back box installations, receptacle spacers and two sizes of mounting screws are provided to accommodate a flush installation of the mounting collar. To use spacers, fold the spacer to the thickness needed, trim and discard the unused sections, and then insert the mounting screws through the collar and the spacers when attaching to the back box.

ESD Ground Termination

This instruction assumes preparation of an ESD ground wire terminating to the five-position removable pluggable screw terminal connector provided in the termination kit.

1. Pull an ESD ground wire (typically green/yellow) to the installed back box.
 - If the control wiring is installed in grounded metal conduit, a short run of wire from the ground screw on the grounded back box can be used.
2. Strip 6 mm (1/4 in) of insulation from the end of the incoming wire and insert it into the terminal labeled "Echo \oplus " and secure.



EchoConnect Termination

This instruction assumes preparation of Belden 8471 (or equivalent) cable terminating to the five-position removable pluggable screw terminal connector provided in the termination kit.



Note: When using Category 5 (or equivalent) cable on the EchoConnect communication bus, please note that not all topologies are supported. Careful planning is required to ensure the proper termination and the wire is pulled appropriately. Refer to the installation guide that is provided with the Cat5 Station Termination Kit (7186A1207) for information to terminate Cat5 wiring.

ETC Installation Guide

EchoTouch

1. Pull all required wiring (data+, data-) into the back box.
2. Strip 6 mm (1/4 in) of insulation from the ends of each wire.
3. Terminate EchoConnect wires to the five-position connector provided. EchoConnect is topology free, you may install the wires in any combination of bus, star, loop, or home-run.
 - a. Insert the data - (typically black) wire into the terminal labeled "Echo -" and secure.
 - b. Insert the data + (typically white) wire into the terminal labeled "Echo +" and secure.



24 VDC Auxiliary Power Termination

EchoTouch requires external power, provided by either a 24 VDC (Class 2) auxiliary power supply or Power over Ethernet (PoE IEEE 802.3af).



Note: *Power over Ethernet (PoE IEEE 802.3af) connects to the RJ45 receptacle on the rear panel.*



Note: *NEC Class 2 product are to be wired in accordance with NEC Article 725 and local jurisdiction requirements. All power and control wiring must be installed and terminated by a qualified installer and must follow standard wiring installation practices.*

Terminate 24 VDC auxiliary power to the five-position screw terminal connector provided in the termination kit.

1. Pull all required wiring (typically a 1.5 mm² / 16 AWG black and red wire pair) into the back box.
2. Strip 6 mm (1/4 in) of insulation from the end of each wire.
3. Terminate 24 VDC wires to the five-position screw terminal connector provided.
 - a. Insert the negative voltage wire (black wire typical) into the terminal labeled "24V -" and secure.
 - b. Insert the positive voltage wire (red wire typical) into the terminal labeled "24V +" and secure.

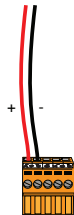

ETC Installation Guide

EchoTouch

DMX Cable Preparation and Termination

This instruction assumes preparation of Belden 9729 (or equivalent) cable for termination to the three-position screw terminal connector provided.



Note: *Not for use with Cat5, Cat5e, or Cat6 cable. When running DMX with these cable types, use the 3-position IDC connector.*

1. Leave approximately 20 cm (8 in) of wiring to allow slack for future service needs.
2. Strip 18 cm (7 in) off the outer jacket.
3. Label the cable with the data type and run designation. (DMX1, DMX2, etc.)
4. Strip the foil shielding from each wire set to within 6 mm (1/4 in) of the outer jacket.
5. Untwist the shield wire from each pair and apply a piece of 1.6 mm (1/16 in) clear heat shrink to each shield wire.
6. Twist each shield wire back onto its data pair, and then apply a 4 cm (1.5 in) piece of 0.5 cm (3/16 in) heat shrink all the way down each 3-wire set. Make sure to capture the foil shielding at the base.
7. Apply the 5 cm (2 in) piece of the 1 cm (3/8 in) heat shrink, centered on the end of the cable jacket and the bases of all the wires in the cable.
8. Cap the ends of the unused pair of wires with a 2.5 cm (1 in) piece of 0.5 cm (3/16 in) heat shrink centered over the end of the wires.
9. Strip 6 mm (1/4 in) of insulation from all of the wires to be used.

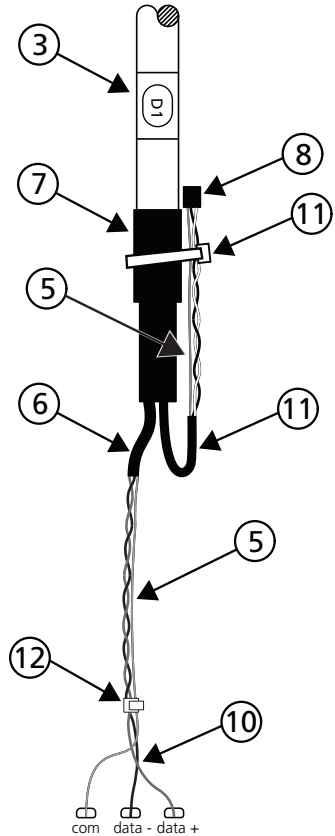

ETC Installation Guide

EchoTouch

10. Maintain the wire pair twist as close to the screw terminal connector as possible and terminate the wires.
 - Insert the data - wire (typically black) into the terminal labeled "DMX -" and secure.
 - Insert the data + wire (typically red or white) into the terminal labeled "DMX +" and secure.
 - Insert the common (shield) wire into the terminal labeled "DMX " and secure.
11. Bend back the unused set of wires and secure them to the cable with a wire tie.
12. Secure the terminated wire sets together with a wire tie 5 cm (2 in) from the connector.

DMX Cat5 Preparation and Termination

This instruction assumes use of Cat5 (or equivalent) cable for termination to the three-position Cat5 insulation displacement connector (IDC) provided in the termination kit.

1. Follow normal Cat5 wire installation procedures to remove 5 cm (2 in) from the end of the cable jacket.
2. Separate the White/Brown, Orange, and White/Orange conductors from the cable. These conductors are required for DMX out.
3. Cut the remaining unused conductors from the cable flush to the cable jacket.
4. Label the cable with the data type and run designation (for example D1 for DMX run 1).
5. Untwist 25 mm (1 in) of the White/Orange and Orange conductors, and then insert the conductors through the labeled terminals as follows:
 - Common (White/Brown) to terminal 1
 - Data - (Orange) to terminal 2
 - Data + (White/Orange) to terminal 3
6. Fully depress each terminal, closing it onto the wire.
7. Use side-cutters to trim the excess wire from the connector.

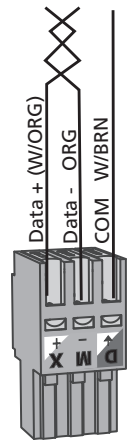

ETC Installation Guide

EchoTouch

Install Touchscreen

1. Align but do not install the touchscreen to the mounting collar. Ensure the touchscreen is oriented with the label text and molded rear panel arrow directed up.

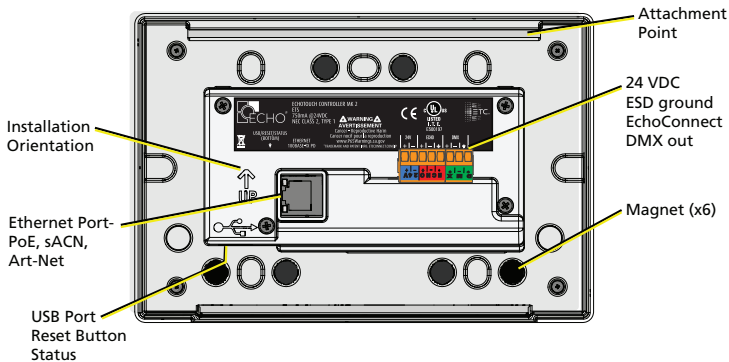

2. Install the prepared five position screw terminal connector (24 VDC, ESD Ground, and EchoConnect control wires) and the utilized three-position connector (DMX) to the designated receptacle(s) on the rear panel of the unit. This instruction assumes you have prepared the cables and terminated them according to the provided instructions for your installation type.
3. If using Power over Ethernet to power the EchoTouch, install the Ethernet cable to the receptacle on the rear panel of the unit.
4. Angle the touchscreen attachment point on the top of the touchscreen to the hook on the mounting collar, and then rotate the touchscreen down until the magnets engage. Gently wiggle the unit to ensure a secure fit.
5. Apply power to the unit. After boot up, press the {?} button located at the top left of the display to access the EchoTouch online help system which provides information to setup and configure your touchscreen.

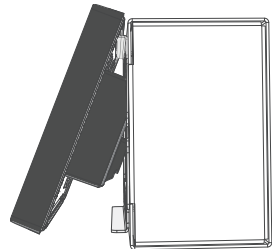

ETC Installation Guide

EchoTouch

Release from the Mounting Collar

Access to the back of the touchscreen is required for the following operations:

- to access the provided USB port for firmware update (see [Update Firmware below](#))
- to download a configuration file (see online help system)
- to troubleshoot control wiring
- to replace the battery

This procedure requires no tools. Gently pull on each bottom vertical edge of the touchscreen to detach the magnetic force, and then pull the unit free from the top attachment point.



Note: *Be careful not to pull on any of the installed cables.*

Update Firmware

1. Copy the firmware update file on the root directory of a USB drive that has been formatted to FAT32. The file will be named similarly to ETC_CS_Console_#.#.#.fw, where # will be replaced with the version numbers.
-



Note: *Please make sure the software file is not inside any other folder or sub-directory as this will hide it from the update function.*

2. The EchoTouch should remain powered, but carefully removed from the mounting collar to gain access to the rear panel. See [Release from the Mounting Collar above](#).
3. Insert the USB drive into the receptacle located on the underside of the rear panel.
4. Access the front of the touchscreen and navigate to Setup >Files >Advanced >Update Firmware. A confirmation message will display. Select “Yes” to continue with the update.

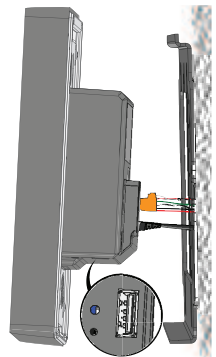

ETC Installation Guide

EchoTouch



CAUTION: *The update process may take a few minutes. Do not shutdown or remove power from the touchscreen until the update process has finished. When prompted, restart the touchscreen by pressing the Reset button located near the USB port.*

5. When the touchscreen has booted, navigate to the General tab in Settings to verify the updated software version number is displayed.
6. Disconnect the USB drive from the rear panel of the unit.
7. Check that all connectors and cables are fully seated, and then reinstall the touchscreen into the mounting collar.

Replace the Battery

The EchoTouch includes an onboard battery which powers the real timeclock when the touchscreen itself is not powered. When the touchscreen no longer maintains its set time, you will need to replace the battery. Replace only as needed with battery type BR1225, 3V (part number BT153-F).

1. Carefully remove the EchoTouch from the mounting collar to gain access to the rear panel. See [Release from the Mounting Collar on the previous page](#).
2. Disconnect all power and data connections from the rear panel.
3. Place the touchscreen, glass side down, on a clean flat surface.
4. As shown, remove the four screws securing the rear cover to the touchscreen.

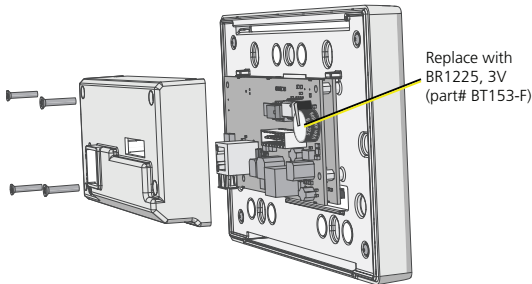

5. Locate, remove, and then replace the battery.
6. Replace the rear cover.
7. Reconnect all power and data connections.
8. Reinstall the touchscreen to the mounting collar.
9. See the integrated help system for information to set the time.