



Power Control Processor

For use with the Unison Echo Relay Panel Mains Feed,
Unison Echo Relay Panel Feedthrough, EchoDIN,
and the Sensor IQ Intelligent Breaker Panel

Configuration Manual

Version 3.1

Part Number: 7123M2400-3.1.0 Rev: A

Released: 2019-01

To view a list of ETC trademarks and patents, go to etconnect.com/ip. All other trademarks, both marked and not marked, are the property of their respective owners.

ETC intends this document, whether printed or electronic, to be provided in its entirety. This product is intended for professional use only. Read this entire document before using this product.

Table of Contents

	Introduction	1
	Congratulatorys	1
	Using This Manual	2
	Symbols	2
Chapter 1	Overview of Panels	3
	Echo Relay Panel Mains Feed Overview	3
	EchoDIN Overview	4
	Echo Relay Panel Feedthrough Overview	5
	Sensor IQ Panel Overview	6
	Option Cards	7
	0–10V Dimming Control	7
	DALI Control	7
	Contact Input	8
	Ride-Thru Option	8
	System Concepts and Definitions	9
	Station Control	9
	Spaces	10
	Output	10
	Circuits	10
	Source Arbitration	10
	Zones	10

Chapter 2	Menu and Configuration	11
	User Interface	11
	Status Indicators	11
	Display	12
	USB Media	14
	Control Button	15
	thru/#nav Button	15
	Reset Switch	15
	Navigation	15
	Number Navigation	15
	Menu Navigation	15
	Menu Structure	17
	About Menu	17
	Switching Setup Menu	19
	Arch Setup Menu	25
	Switching Control Menu	30
	Arch Control Menu	32
	File Operations	35
	View Errors	36
Chapter 3	Service and Maintenance	37
	Service	37
	Contacting ETC about equipment problems	37
	Maintenance	37
	Vacuum the Interior	37
	Changing Fuses	37
Appendix A	Menu Flow Chart	38
Appendix B	Timeclock	45
	Programming examples	45
	Astronomical event	45
	Timed event	46
	Holiday shut-off	46

Appendix C	Status Messages	47
	Emergency Active	47
	Breakers Tripped	47
	Relay Mismatch	48
	Relay Removed	48
	Breaker Mismatch	48
	Breaker Removed	48
	Drive 1/2 Error	48
	Breaker Error	49
	Dim Overtemp	50
Appendix D	Web UI	51
	System	51
	Relays	52
	Set Levels	52
	Presets	53
	Sequences	53
	Files	54

Introduction

Congratulations...

on your purchase of a product that utilizes the Echo Power Control Processor. If you have any questions regarding the operation or installation of your processor, contact ETC Technical Services at the office nearest you.

Emergency service is available from all ETC offices outside of normal business hours.

When calling for help, please have the following information handy:

- Your location and job name.
- Model of breaker or relay panel(s).
- Type of breakers and relays used including model numbers and quantities.
- Other components in your system including dimmers, switch gear, quantity and type of wall stations, etc.
- DMX and/or sACN control source used for system-wide control, if any.
- Related system problems or equipment failure.

Americas

ETC, Inc.
Technical Services Department
3031 Pleasant View Road
Middleton, WI 53562
800.775.4382 (USA, toll-free)
+1.608.831.4116
service@etconnect.com

Asia

ETC Asia
Technical Services Department
Room 1801 / 18F
Tower 1 Phase1, Enterprise Square
9 Shueng Yuet Road
Kowloon Bay, Kowloon, Hong Kong
+852 2799 1220
service@etcasia.com

United Kingdom

ETC Ltd.
Technical Services Department
Unit 26-28 Victoria Industrial Estate
Victoria Road,
London W3 6UU, UK
+44 (0) 8896 1000
service@etceurope.com

Germany

ETC GmbH
Technical Services Department
Ohmstrasse 3
83607, Holzkirchen, Germany
+49 (80 24) 47 00-0
techserv-hoki@etconnect.com

Using This Manual

Along with basic maintenance and service procedures for long lasting performance, this manual contains information on using the Power Control Processor with the following products:

- Echo Relay Panel Mains Feed (ERP)
- EchoDIN
- Echo Relay Panel Feedthrough (ERP-FT)
- Sensor IQ Intelligent Breaker System

Each of these products provides professional quality switching of dimmed and non-dimmed loads controlled by DMX512, Ethernet, or the Echo line of stations. This manual contains the procedures for operation, service, and maintenance of each of these panels and their associated options.

Symbols

The following symbols are used throughout this manual to alert you to danger or important information.



Note: *Notes are helpful hints and information that is supplemental to the main text.*



CAUTION: *A Caution statement indicates situations where there may be undefined or unwanted consequences of an action, potential for data loss or an equipment problem.*



WARNING: **A Warning statement indicates situations where damage may occur, people may be harmed, or there are serious or dangerous consequences of an action.**



WARNING: **RISK OF ELECTRIC SHOCK! This warning statement indicates situations where there is a risk of electric shock.**

Please email comments about this manual to: TechComm@etconnect.com.

Chapter 1

Overview of Panels

The Power Control Processor is designed for use in several power control products, including Echo Relay Panel Mains Feed, Echo Relay Panel Feedthrough, EchoDIN, and Sensor IQ Intelligent Breaker System.

Echo Relay Panel Mains Feed Overview

The Echo Relay Panel Mains Feed (ERP) provides professional quality switching and dimming of loads controlled by DMX512, Ethernet, or Echo stations.

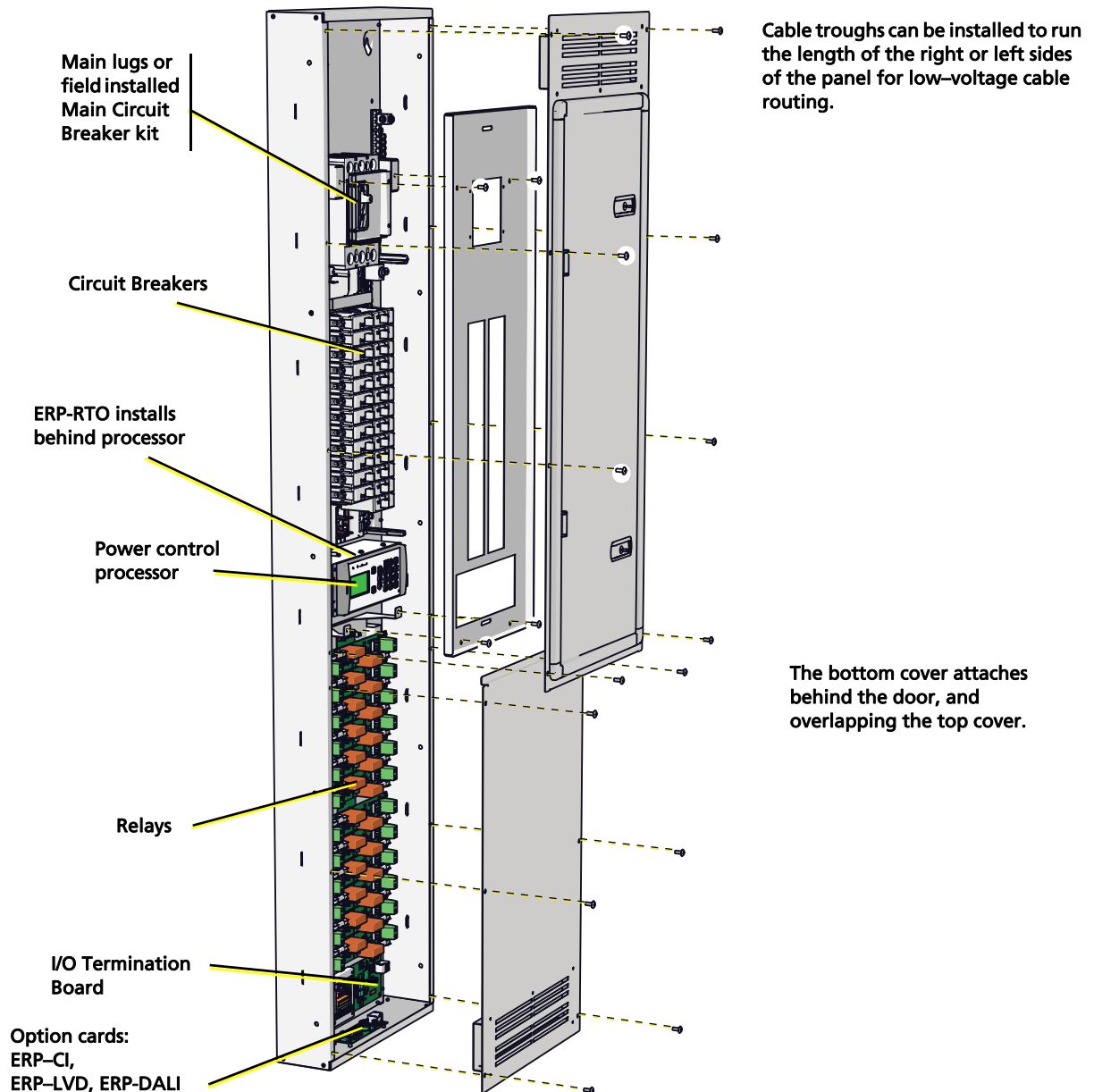

EchoDIN Overview

The EchoDIN line of products provides professional quality switching and dimming of loads controlled by DMX512, Ethernet, or Echo stations for the European market. For system flexibility, all EchoDIN components mount in any DIN rail enclosure provided that the enclosure is grounded and has proper ventilation. For additional information on EchoDIN products, see the EchoDIN installation manuals. Manuals are available for download at etconnect.com.

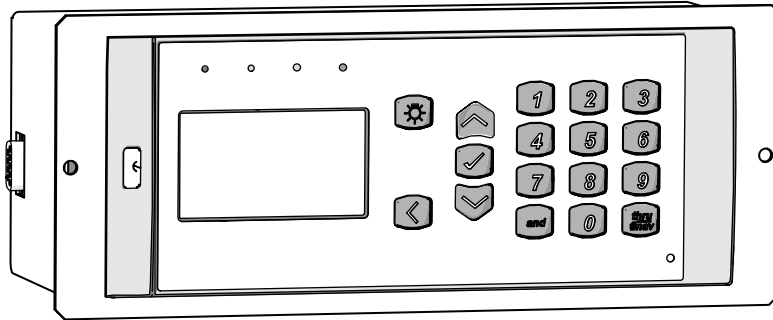

Power Control Processor

○ The Ride-Through Option (E-DIN-RTO) installs on the back side of the processor

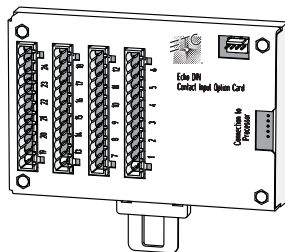

Contact input option card (E-DIN-CI)

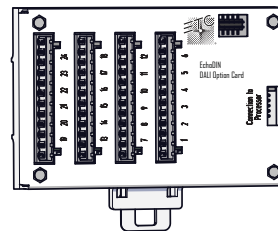

DALI option card (E-DIN-DALI)

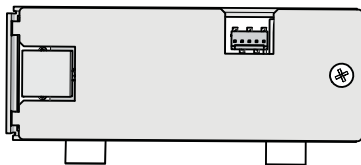

Network option card (E-DIN-NET)

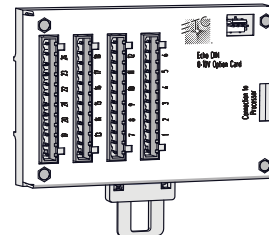

0-10V option card (E-DIN-LVD)

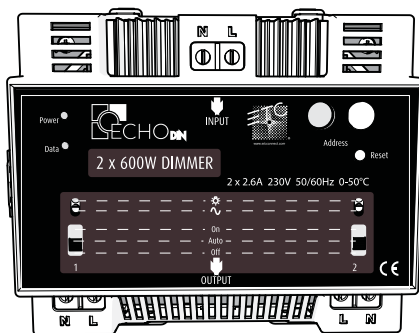

2-Dimmer Module (E-DIN-2DIM)

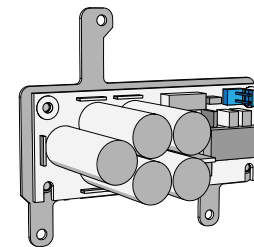

Ride-Through Option (E-DIN-RTO)

4-Relay Module (E-DIN-4 RELAY)

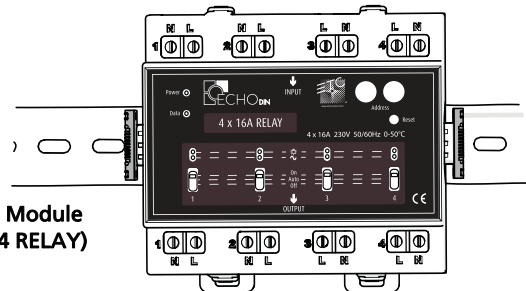

Echo Relay Panel Feedthrough Overview

The Echo Relay Panel Feedthrough (ERP-FT) provides professional quality switching and dimming for up to 48 channels of non-dim loads in a single panel. Loads are controlled by DMX512, Ethernet, or Echo stations.

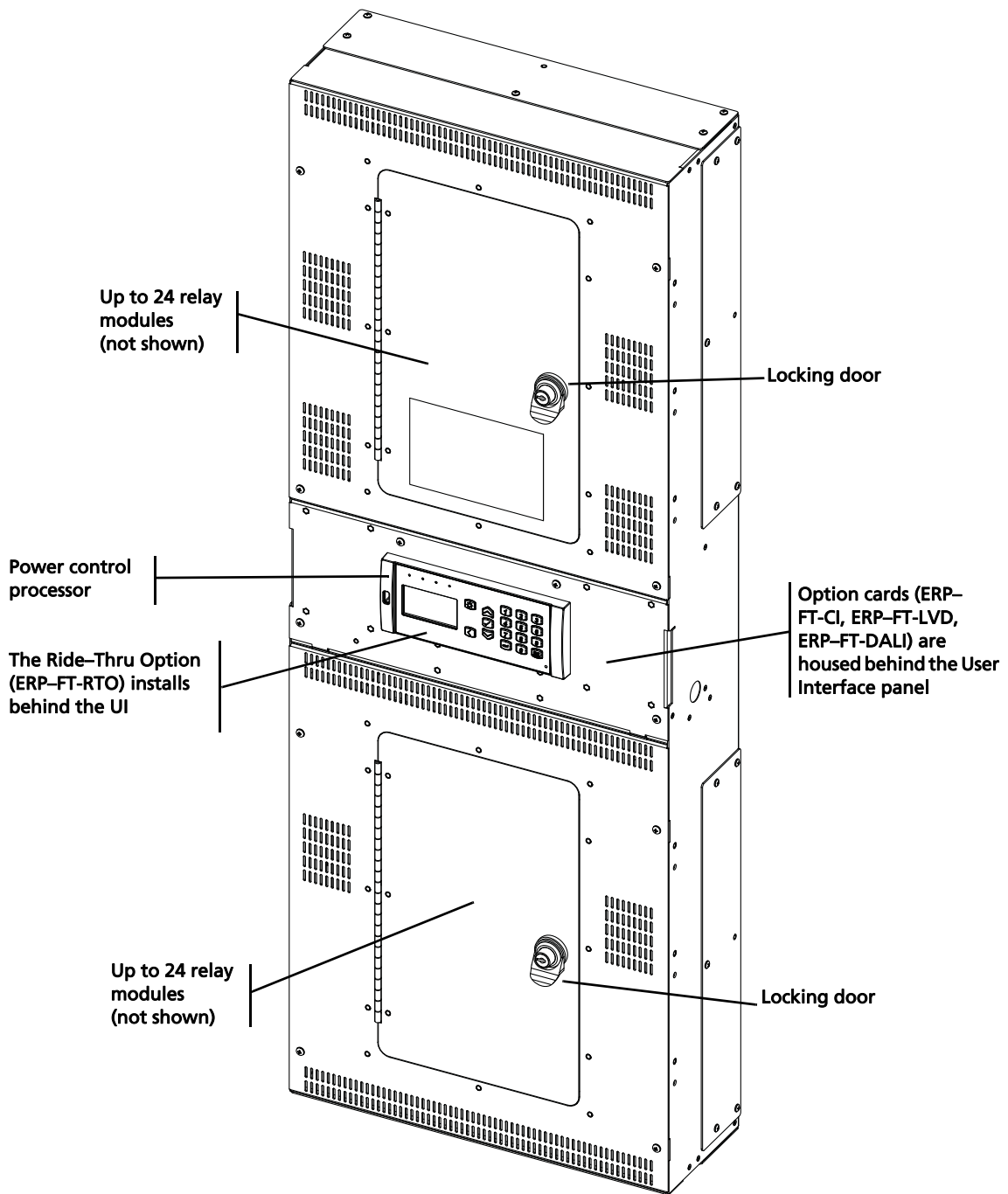

Note: *It is possible to retrofit an existing SmartSwitch to an Echo Relay Panel Feedthrough. Please call your ETC project manager or customer service representative for more information.*

Sensor IQ Panel Overview

The Sensor IQ Intelligent Breaker System provides professional quality switching and dimming of loads controlled by DMX512, Ethernet, or Echo controls.

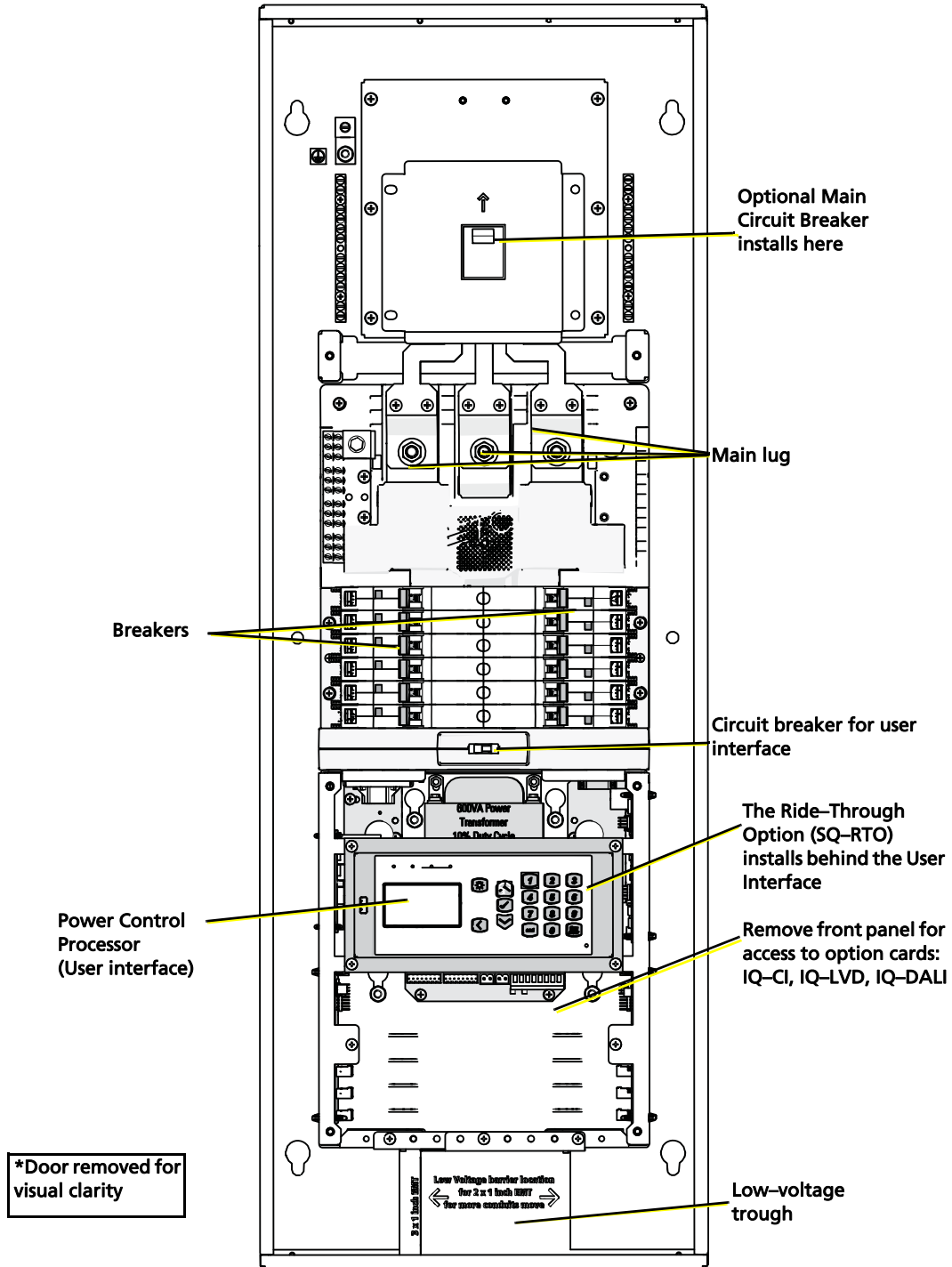

Option Cards

Option cards are available for field installation into each of the panels. Each option adds another level of features and functions to your system.

For more information on the specification or installation of the option cards, see the individual installation manual supplied either with the relay panel (Echo Relay Panel Mains Feed and Echo Relay Panel Feedthrough) or with the option card (Ride-Thru Option card, all EchoDIN option cards, and all Sensor IQ option cards). Manuals are available for download at etconnect.com.

0–10V Dimming Control

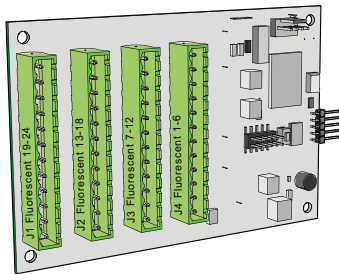

The 0–10V Dimming Control option card provides 24 outputs for control of 4-wire current-sink, 0–10VDC fluorescent or electronic loads.

- Each of the 24 outputs are rated to control a maximum of 400mA per channel (up to 50 ballasts per channel).
- Loss of power at the Control Processor results in releasing control levels to full.



Note: *A single ERP Mains Feed and ERP Feedthrough panel supports the use of either the 0–10V Dimming Control option or a DALI Control option, but not both in the same panel.*

DALI Control

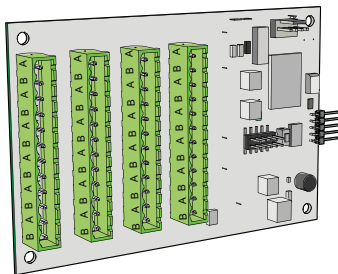

The Digital Addressable Lighting Interface (DALI) Control card controls 24 loops of 64 DALI compatible ballasts in broadcast mode. Each loop of up to 64 DALI ballasts are linked one to one with the relay panel circuit for power control.

The DALI ballast must be powered by an external DALI loop power supply (supplied by others). This supply is connected externally of the processor. Each DALI loop requires its own power supply and possibly more than one power supply depending on the ballast load.

Installation is limited to 64 DALI compatible fluorescent ballasts per DALI loop.

Contact Input

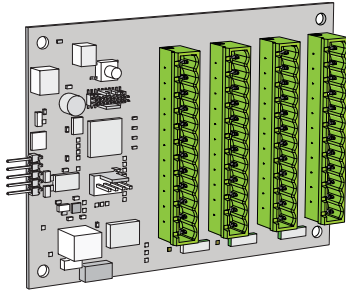

The Contact Input card provides the ability to directly control the relays using a momentary or maintained dry contact input.

Ride-Thru Option

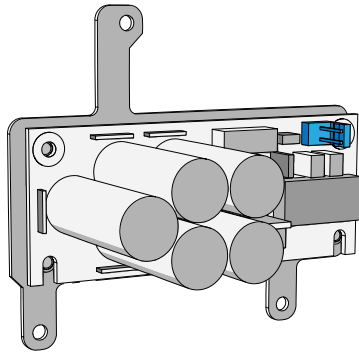

The Ride-Thru Option maintains power to the Power Control Processor for a minimum of 15 seconds in the event of a brown-out or power loss.

The Ride-Thru Option card mounts behind the user interface.

System Concepts and Definitions

Station Control

The Power Control Processor supports Echo Inspire Stations, and five and ten button Preset stations on the EchoConnect bus. The power supply of one connected panel can support up to six Echo control products and up to five additional Echo output products on the bus. An additional wall-mounted or rack-mounted power supply can be added to a system to support up to sixteen control products and fifteen additional output products.

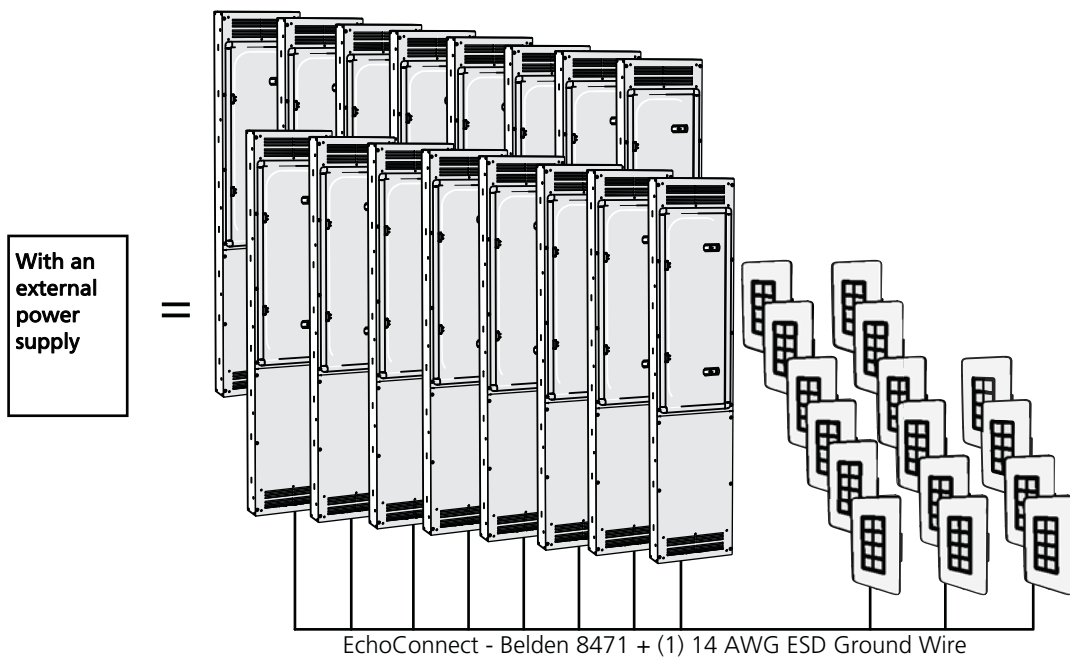
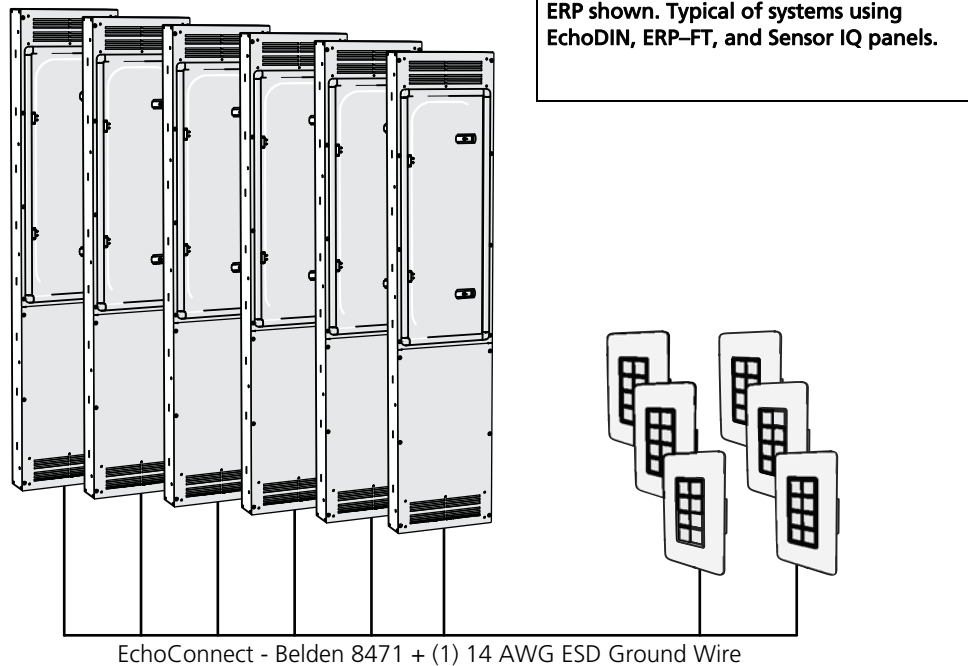

Note: CAT5 wiring is supported for the EchoConnect station bus with some limitations. See the Cat5 Cable Preparation Setup Guide for more details.

Spaces

Spaces are used to divide the outputs of the relay panel into logical segments (such as different rooms in a building). Preset, sequence and zone level adjustments all happen within a “space”.

Each panel supports separation of its controllable outputs (relays, 0–10V Dimming Control and DALI Control). Spaces 1 through 255 are available for assignment, with spaces 1–16 reserved for Echo control.

Output

An output refers to the physical position of the relay, dimmer, or intelligent breaker in the panel. Up to 48 circuit outputs are available based on the type of system installed.

- The ERP–FT can be populated with single-pole and double-pole relays, and the ERP Mains Feed can be populated with single-pole, double-pole, and three-pole relays.
- In an ERP Mains Feed, a double-pole relay requires two output positions, and a three-pole relay requires three output positions.
- The ERP can be populated with dimmer modules. Each dimmer module is the same size, and installs in the same manner, as a single pole relay module.
- The Sensor IQ 120V can be populated with single-pole, double-pole, and three-pole breakers. Sensor IQ 277V does not support multi-pole breakers.
- In a Sensor IQ, a double pole relay requires two output positions, a three-pole relay requires three output positions.

Circuits

Circuits are the logical reference number used to talk about a controllable output in the ERP Mains Feed and ERP Feedthrough. Circuits are unique within a space and are user configurable in software. The combination of space and circuit provides a unique identification of an output within a system.

For example, a single panel can have two circuit #1's when they belong to separate spaces.

Source Arbitration

Each panel can accept a variety of control sources including DMX, Streaming ACN (sACN), presets, sequences, manual set levels, and panic.

Circuit output arbitration is based on the sACN model of source priority, meaning each source is assigned a priority between 1 and 201 (201 is the highest priority). With this priority, control sources are arbitrated based on their set priority. The default priority is 100.

The panel uses the priority assigned within the sACN packet, sent from the control source. Each panel sets the configured priority for DMX, presets, and sequences.

The Contact Input Option card can be used to:

- trigger presets and sequences, which will play at the priority configured for architectural sources, or;
- directly control one or more outputs. The priority of these outputs is configurable. If nothing is configured, the last action takes precedence.

Manually setting levels from the user interface of the Power Control Processor overrides all other control sources with the exception of panic, which is the highest possible priority.

Zones

A Space within an Echo control system can be broken down further into zones. You can assign a zone to an Echo Inspire station for direct control using that station's buttons or faders. You can have multiple zones within a space, and a single zone can control multiple outputs across multiple panels.

Chapter 2

Menu and Configuration

User Interface

The Power Control Processor features a simple user interface with up and down arrows for menu navigation, a numeric keypad for direct selection, and an easy-to-read graphical display. Additionally, a USB port is provided on the left side of the controller for storage of configurations to a flash drive.

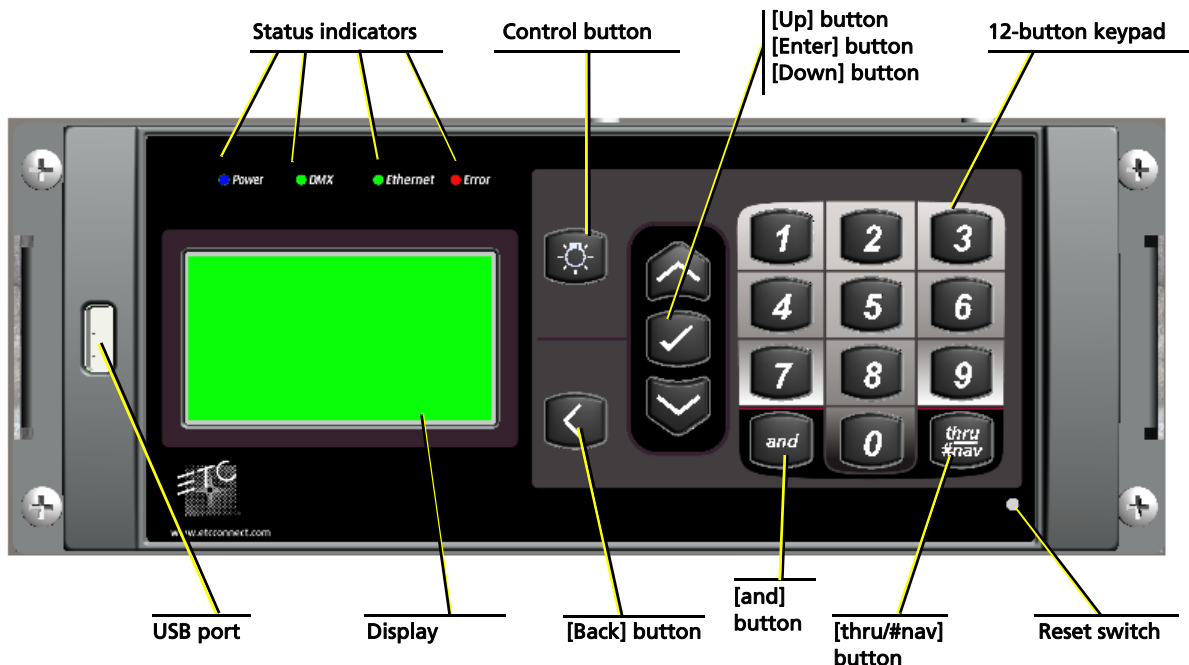

The Power Control Processor can be configured from the user interface or from Net3 Concert. For more information about configuration in Net3 Concert, select Help from the menu of the Net3 Concert application. Net3 Concert is available for free download from etconnect.com.

Status Indicators

The user interface features the following status indicators:

Indicator	LED Color	Status
Power	Blue	Power on
DMX	Green Steady	DMX input enabled and DMX present
	Green Flashing	DMX input enabled but no DMX present
	Green Rapid Flashing	DMX input enabled with DMX input error
	Off	DMX input disabled
Ethernet	Green Flashing	Ethernet activity
	Off	No Ethernet activity or Ethernet Interface card is not present
Error	Off	Not in error state
	On	Error state

See [Status Messages](#) on [page 47](#) for descriptions of errors.

Display

The Power Control Processor features a high contrast 21-character, 8-line backlit screen. When scrolling through the menu, the first row of the display is reserved for the menu title.

A scroll bar displays along the right side of the screen indicating there is more content to be displayed. Use the [Up] ↑ or [Down] ↓ buttons on the user interface to scroll through the available menus.

Wake

The menu system and display backlight are set, by default, to sleep after three minutes of inactivity. Any button press wakes the user interface and backlight.

Home Screen

The home screen is shown by default at power-up. The display reverts to the home screen automatically from any point in the menu after two minutes of user inactivity.

Two displays are available from the home interface:

- “Output Status” screen, which shows information about the current state of the channels
- “Arch Control Status” screen, which shows current present status information.

Switch between the two by pressing the [Up] ↑ or [Down] ↓ buttons.

Output Status

Output Status screen displays several lines of information:

- Line 1 shows:
 - name of the display: Output Status
 - clock symbol - shown only when the timeclock has been enabled for the panel. Reference [Timeclock](#) on [page 27](#) for more information on timeclock functionality.
 - [L] symbol is shown when levels are set locally at the panel.
 - The ↑ or ↓ arrow in the upper-right corner shows the option to navigate to an additional menu.
- Lines 2 and 3 combine to show blocks representative of the set level.
 - Each block shows the status of the channel from left to right with 1 at the left and the highest number (up to 24) on the right. For racks with more than 24 channels, a second block is shown for the additional 25–48 channels. Levels are indicated for each channel in a separate block of pixels. For 0–10V Dimming Control or DALI Control channels, the level is shown.

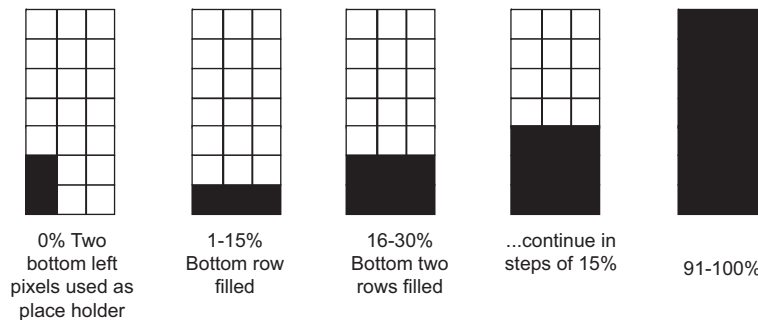
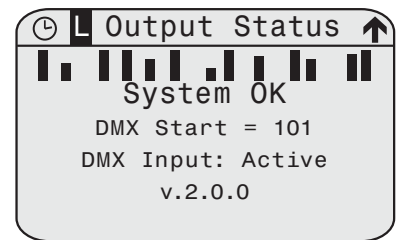

Note: *When relays are installed that occupy more than one output position, only a single bar is shown per relay.*

- Lines 4 displays the rack status. The options in the chart below that are marked “illuminate error LED” will trigger the red error LED to be lit. The options that are marked as “cycle with others” share the display by cycling through each applicable message at a rate of one every two seconds.

Status Message	Cause	Illuminate Error LED?	Cycle With Others?
System OK	No other messages active	No	N/A
Emergency Active	Emergency look is active	Yes	No
Breakers Tripped***	No voltage detected at one or more relays	Yes	Yes
Relay Mismatch**	One or more relays in the rack are mismatched	Yes	Yes
Relay Removed**	One or more relays in the rack are not found	Yes	Yes
Breaker Mismatch*	One or more breakers don't match the configuration	Yes	Yes
Breaker Removed*	One or more breakers in the rack are missing	Yes	Yes
Drive 1/2 Error*	Unable to communicate to breaker drive board	Yes	Yes
Timed Event Hold	User has applied a timed event hold	No	Yes
Holiday Shut-off	User has activated holiday Shut-off	No	Yes
Breaker Error*	Breaker has repeatedly tried and failed to operate	Yes	Yes
Dim Overtemp**	Dimmer is in an overtemp state	Yes	Yes
Invalid Cfg Loaded	User has loaded a configuration file which is invalid	Yes	Yes
* Sensor IQ panel only ** Echo Relay Panel Mains Feed only *** Applies to all panels except Echo Relay Panel Feedthrough For more information on status messages, see Status Messages on page 47 .			



Note: *When an Emergency Status is active, no other status indicators will be shown. Emergency Status will always take precedence over all other status options.*

- Line 5 shows the lowest configured DMX Start address value in the Power Control Processor. If the panel is patched straight (one for one) the equals sign (=) is used. When the panel is set up with a custom address, approximate equals sign (≈) is used instead.
- Line 6 alternates each second between the status of the DMX connection and, when the ports are enabled, the status of the sACN connection.
 - **DMX Input** will be displayed as either *Active, Inactive* or *Disabled*.
 - **sACN Input** will be displayed as either *Active, Inactive* or *Disabled*, *but only when the ACN option card is installed*.
- Line 7 shows the status of the built-in Echo station power supply (On or Off) and the current Power Control Processor software version number.

Arch Control Status

Arch Control Status displays several lines of information:

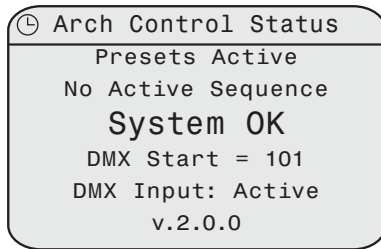

- Line 1 shows:
 - name of the display: Arch Control Status
 - clock symbol - shown only when the timeclock has been enabled for the panel. Reference [Timeclock](#) on [page 27](#) for more information on timeclock functionality.
 - [L] symbol is shown when levels are set locally at the panel.
 - The **↑** or **↓** arrow in the upper-right corner shows the option to navigate to an additional menu.
- Line 2 shows “Presets Active” if any presets are active in the rack. If no presets are active, “No Active Preset” will be shown.
- Line 3 cycles (in 1 second intervals) between the following screens:
 - “Sequence Active” if the sequence is active or if no sequence is currently active, “No Active Sequence” is shown.
 - The panel’s IP address if the Network Option Card is installed.
- Line 4 displays the system status. See [Status Messages](#) on [page 47](#).
- Line 5 shows the lowest configured DMX Start address value in the Power Control Processor. If the panel is patched straight (one for one), the equals sign (=) is used. When the panel is set up with a custom address, approximate equals sign (≈) is used instead.
- Line 6 alternates each second between the status of the DMX connection and, when the ports are enabled, the status of the sACN connection.
 - **DMX Input** will be displayed as either *Active*, *Inactive* or *Disabled*.
 - **sACN Input** will be displayed as either *Active*, *Inactive* or *Disabled*, but only when the ACN option card is installed.
- Line 7 shows the status of the built-in Echo station power supply (On or Off) and the current Power Control Processor software version number.

Backup Power Active

When mains power is no longer detected, after three seconds the panel will display a warning message “**BACKUP POWER ACTIVE!**”. While this warning is displayed all other menu screens become inaccessible.

Once mains voltage is restored, the display will revert back to the home screen and menu functionality will return.

USB Media

The Power Control Processor includes a USB type A socket located on the left side of the user interface. A USB storage device is not included and must be purchased separately.

Use a compatible USB storage device to save and load backup files of your configuration and to update the Power Control Processor firmware. See [File Operations](#) on [page 35](#) for information on file operations.

Compatible USB Storage Device

Use a USB storage device that is pre-formatted with the compatible FAT file system. As needed you can reformat a USB storage device using a PC with the Windows® operating system or an Apple® Macintosh® computer. See the related operating system’s online help for instructions to format the USB media.

Control Button

Provides quick access to the control menus.

- Press the control button to rotate access to the Switching Control menu and the Arch Control menu.
- Press and hold the control button to enter “All On” mode. In All On mode, all outputs of the panel turn on at full. Press the **[Back]** (<) button or **[Enter]** (✓) button to exit All On mode.

thru/#nav Button

Provides quick access to number navigation mode from the home screen. Each menu item is preceded by a number. Pressing that number on the keypad while in #nav mode will execute that menu function. If you are in a menu line where it is possible to enter a numeric value, pressing this button will act as a thru selection key.

Reset Switch

Reset the Power Control Processor by pressing the reset switch located on the bottom-right corner of the user interface. Access this reset switch using a blunt push tool (for example, the tip of a ballpoint pen). Outputs from installed option cards may change with a reset.

Navigation

To enter the main menu, press the **[Enter]** (✓) button from the home screen.

Number Navigation

Pressing the **[thru/#nav]** button on the user interface at any point accesses the number navigation feature of the menu. Each number corresponds to a different menu option, allowing quick navigation through each menu option.

The main menu includes the following items:

- 1 About - see [page 17](#)
- 2 Switching Setup - see [page 19](#)
- 3 Arch Setup - see [page 25](#)
- 4 Switching Control - see [page 30](#)
- 5 Architectural Control - see [page 32](#)
- 6 File Operations - see [page 35](#)
- 7 View Errors - see [page 36](#)

Main Menu	
1	About
2	Switching Setup
3	Arch Setup
4	Switching Control
5	Arch Control
6	File Operations
7	View Errors

Menu Navigation

List Menu

In a list style menu, use the **[Up]** ↑ or **[Down]** ↓ buttons to navigate through the menu options. Options are highlighted with inverse color when they are selected. Pressing the **[Back]** (<) button will return to the previous menu selection. Pressing the **[Enter]** (✓) button will enter the selected menu option.

Main Menu	
1	About
2	Switching Setup
3	Arch Setup
4	Switching Control
5	Arch Control
6	File Operations
7	View Errors

Settings Menu

Similar to the list style menu, use the **[Up]** ↑ or **[Down]** ↓ buttons to move through the options in a settings menu. Throughout these settings menus, values can be edited by using the **[Up]** ↑ or **[Down]** ↓ buttons or for numeric entries or, as needed, you can use the numeric keypad. Pressing **[Enter]** (✓) allows you to begin editing the option, as well as to commit the menu selection and move to the next item.

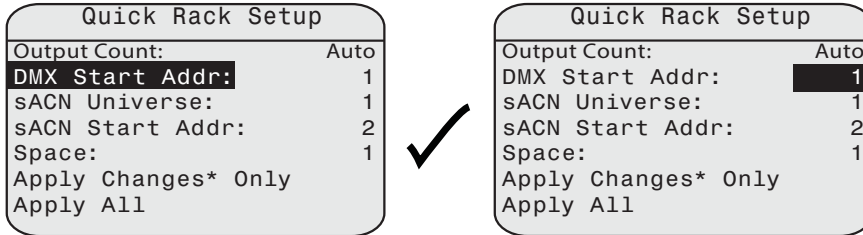

Multi-part Options

In a multi-part menu, each editable item can be modified by first pressing **[Enter]** (✓), then by using the numeric keypad or the **[Up]** ↑ or **[Down]** ↓ buttons to enter the correct value.

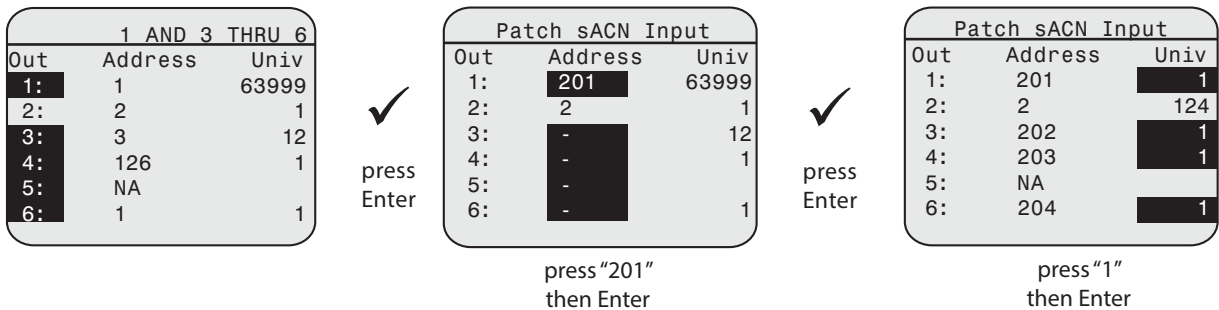

Press the **[Back]** (<) button to return to the previous selected field.



Note: Changes are saved only when **[Enter]** (✓) is pressed on the last field for the selection or when "Apply Changes" is selected.

Menu Structure

About Menu

The "About" menu provides information about the Power Control Processor configuration.

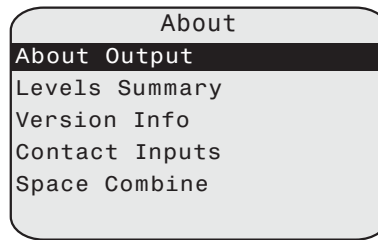

About Output

The About Output menu is a three-screen, non-editable menu that gives status information for each source feeding a relay or breaker.

- To navigate between screens, press **[Enter]** (✓). Pressing enter from the third screen will wrap back to the first screen.
- Select the output position number by either entering a number, or using the **[Up]** ↑ or **[Down]** ↓ buttons. The selected circuit is highlighted in the top right corner of the screen.

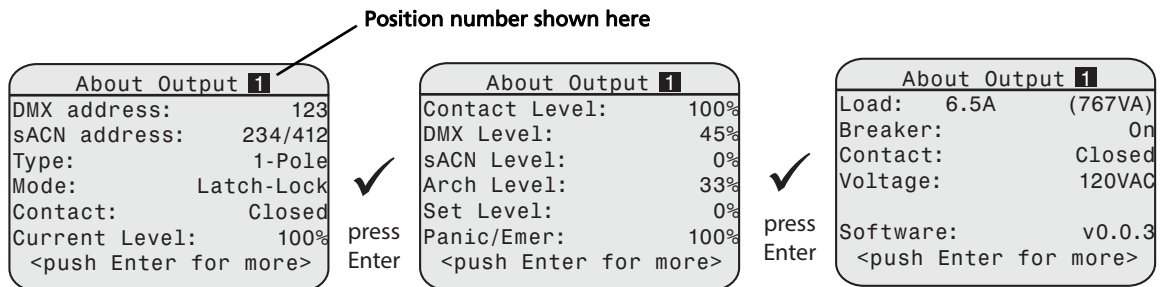

- Type: Displays the relay or breaker type detected at the selected position. Depending on panel type, the options are *None*, *1-Pole*, *2-Pole*, *3-Pole*, and *Dimmer*.

- Mode: Displays the configured mode of the circuit.

Load Type	Modes	Description
Relay	Normal	For a relay, the output is off below the threshold and on at or above the threshold. For a dimmer, the output is off below the threshold and dims above the threshold.
	Fluorescent	Used for circuits in conjunction with the 24-Channel, 0–10V Dimming Control option. The circuit will switch on at the threshold value and control the 0-10V dimmed levels using the option card.
	Latch/Lock	Latch/Lock mode can be used for circuits where extra security is desired when turning them on or off. To turn the relay or breaker on, the DMX or sACN level must be held at a specified value for a certain period of time, and at another value to turn it off. The on and off values are configurable (see Output Setup on page 19).
	DALI	Used for circuits in conjunction with the DALI option card. The circuit will switch on at the threshold value and control the DALI output using the option card.
	Always On	Output is always turned on.
Dimmer	Auto	Automatically detects phase angle control of the connected load
	Forward	Forward-phase dimming control
	Reverse	Reverse-phase dimming control

- Current Level: Displays the current level of the selected circuit from the controlling data source in percent (%). When no control is present, this is shown as a dash (–).

The following five menu options display the individual levels (if applicable) for DMX, sACN, Arch, current set level, Panic/Emergency, and Contact Input.

- Breaker: Displays the state of the breaker in the panel as either *On* or *Off*.
- Contact: Displays state of the relay contact as either *Closed* or *Open*.
- Load: Displays the load both as amperes (A) and calculated (VA). The load value displays and updates in real time. Multiple pole relays will show loads for each pole (load (1), load (2), etc.) For the Echo Relay Panel Feedthrough, voltage is not measured, so this field will contain a dash (–).
- Voltage: Displays the voltage as received for the output. For Echo Relay Panel Mains Feed and Sensor IQ, this is equal to the measured voltage coming into the rack. For EchoDIN, this is the voltage measured from the relay. For Echo Relay Panel Feedthrough voltage is not measured, therefore this field will contain a dash (–).
- Software: Displays the version number of the installed software in the relay card.

Levels Summary

Displays the output information for each position, including its highest takes precedence (HTP) control level and winning input source. Use the **[Up]** ↑ or **[Down]** ↓ buttons to view additional lines of text. The information provided includes:

- DMX input: DMX
- Streaming ACN: sACN
- Set Levels: Set
- Preset, Sequence or Zone: Arch
- Emergency Look: Emerg
- Contact Input: Cont
- No Control of dimmer: – – –
- Hold Last Look: when the control source (DMX or sACN) has been lost, but the circuit is holding its level received from the last look.

Pos	Ckt	Src	Level
1	12	Cont	255
2	1	sACN	125
3	2	Arch	75
4	3	---	---
5	4	DMX	255
6	5	Emerg	255
7	6	Set	0

Version Info

Displays the software version for each component installed in the panel. Possible options include Application, Network, DALI 1, FLO 1, Contact, Bootloader, Echo Protocol, Echo MAC.

Version Info	
Application:	1.2.3.4.5.0
Network:	2.3.4.5.6.0
DALI 1:	1.2.3.4.5.0
DALI 2:	1.2.3.4.5.0
Contact:	1.2.3.4.5.0

Contact Inputs

The Contact Inputs menu shows the status of the contacts in the contact input card. Each of the option cards 24 inputs will show a status of "OFF" or "ON", and will be updated in real time. This is read only information.

If there is no Contact Input card installed the screen will read "Contact input card not installed".

A (+) symbol displays when more information is not shown because of screen space limitations.

Contact Inputs		
1:OFF	2:OFF	3:OFF
4:OFF	5:OFF	6:OFF
7:OFF	8:OFF	9:OFF
10:OFF	11:OFF	12:OFF
13:OFF	14:OFF	15:OFF
16:OFF	17:OFF	18:OFF
19:OFF	20:OFF	21:OFF
22:OFF	23:OFF	24:OFF

Space Combine

The Space Combine menu shows which Echo Spaces are configured for this panel, as well as which other spaces it may be combined with. If it is not combined with any other spaces, it will read "None".

Space Combine	
Space 1:	2
Space 2:	1
Space 4:	5,6
Space 5:	4,6
Space 6:	4,5

Switching Setup Menu

Switching Setup	
1	Output Setup
2	Patch DMX Input
3	Patch sACN Input
4	Emergency Setup
5	Quick Rack Setup
6	Switching Options

Output Setup

The "Output Setup" menu allows configuration of operation parameters for each position in the panel. Use the [Up] ↑ or [Down] ↓ buttons or the numeric keypad to select either a single position or multiple positions using the [and] and [thru/#nav] buttons. The selected circuit parameters display.

If an output is selected that is a multi-pole relay, the information shown will be duplicated.

When multiple relays or breakers are selected using the [and] and [thru/#nav] buttons, the top line updates to show as much information as possible for the selection. A (+) symbol displays when there is more information than the display has room to show.

- **Mode:** Configure the type of load in the output position. See "About Mode" on [page 18](#) for more information on modes.
 - When a relay is installed, options are Normal, Fluorescent, Latch/Lock, DALI, and Always On.
 - When a dimmer is installed, options are *Auto*, *Forward*, or *Reverse* phase.

Output Setup 1	
Mode:	Normal
Type:	1-Pole
Threshold:	1%
Space:	1
Zone:	1
Circuit:	1
Allow Manual:	Yes
Min Scale:	1%

- **Type:** The following types are available per rack.
 - ERP - 1-pole, 2-pole, 3-pole, Dimmer, None
 - EchoDIN - 1-pole, Dimmer, None
 - ERP-FT - 1-pole, None
 - Sensor IQ - 1-pole, 2-pole, 3-pole, None
- **Threshold:** Displays the percentage level at which the relay switches on. The default value is 1%.
- **Space:** Allows configuration of the space to which the selected outputs are allocated. The default is Space 1. See [Spaces](#) on [page 10](#).
- **Zone:** Allows configuration of the zone to which the selected outputs are allocated. See [Zones](#) on [page 10](#).
- **Circuit:** Displays the currently assigned circuit number for the dimmer or relay position in the panel.
- **Allow Manual:** Determines what happens when a manual override is made on products supporting manual override, such as manually switching the relays on ERP-FT.
 - If set to "Yes", which is the default, the relay is treated as if the level has been set to full.
 - If set to "No", a manual override is attempted, the controller will reassert control and change the relay to the state requested by the incoming control inputs.
- **Min Scale:** A dimmer only parameter. Displays the percentage level at which a dimmer switches on. The default is 1%.

Multi-select Space Alteration

If multiple positions in the panel are selected and the assigned Space value is altered, there is the possibility of the new assigned Space containing multiple circuits of the same number.

For example, Space 1 contains Circuits 1–5 and Space 2 contains Circuits 1–10. The user selects Space 1 Circuits 1–5 and changes them to Space 2.

In this case a warning will be shown with the option to have all circuits auto-numbered to fit within the selected Space.

Select [Yes] to complete autonumbering.

Selecting Yes, in the example above, the Power Control Processor will renumber the circuits to 11–15 and move them into Space 2.

Select [No] to keep circuits as set.

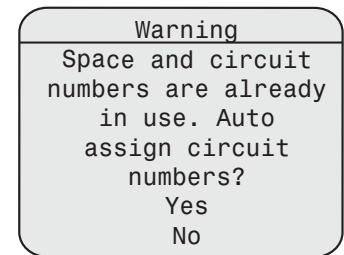

Patch DMX Input

This editable screen allows for the DMX address of each circuit to be altered.

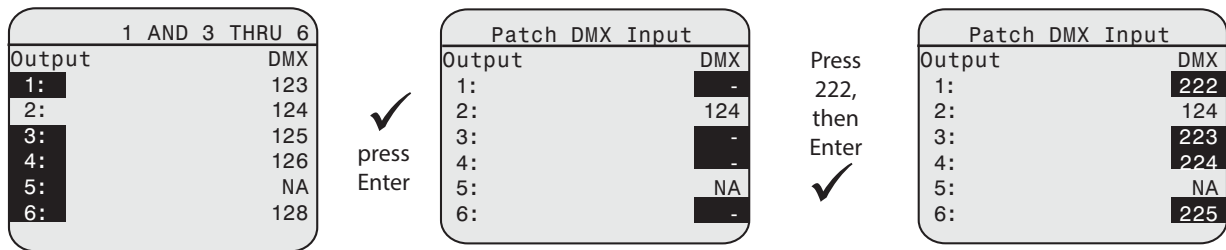

- 1: While in the Patch DMX Input menu, select the DMX circuit number on the keypad. If applicable use the AND or THRU keys to select multiple circuits.
- 2: Wait 2 seconds for the panel to recognize the requested circuits.
- 3: Press **[Enter]** (✓).
- 4: Using the keypad, type the required **starting** DMX address for the selected circuit or group.
 - The panel will consecutively auto-fill all additional circuits within the selected group.
- 5: Press **[Enter]** (✓) to commit the selection.
 - Pressing "0" then **[Enter]** (✓) will unpatch a circuit.
 - Unpatched circuits are shown as "-".
 - For multi-pole breakers/relays, the DMX address will be shown for the first, or lowest output of the relay.

For multi-pole breakers and relays, the DMX address lives with the first, or lowest pole. All other poles are shown as N/A. If the breaker or relay is not configured as a multi-pole, all poles are available.

Patch sACN Input

This editable screen allows you to select the patch number for each selected circuit.

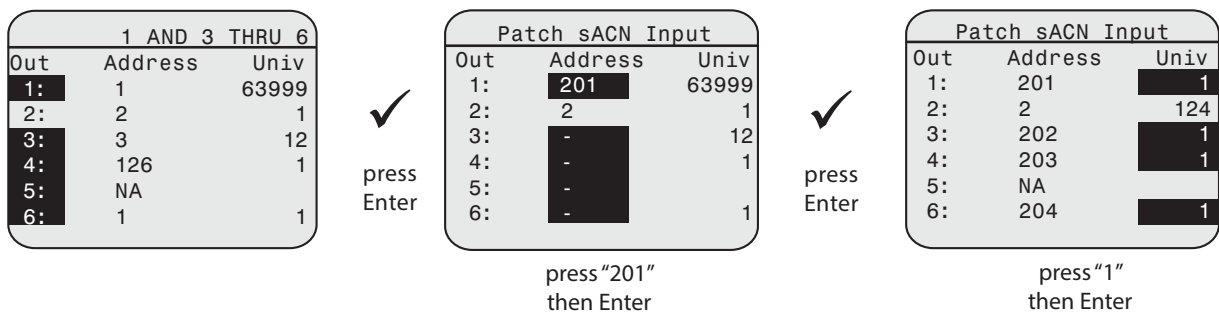

- 1: While in the Patch sACN Input screen, select the circuit position number on the keypad. To select multiple circuits, use the AND or THRU keys.
- 2: Wait 2 seconds for the panel to recognize the requested circuits.
- 3: Press **[Enter]** (✓).
- 4: You will now see the **Address** column highlighted. Use the keypad to select the starting patch number.
- 5: Press **[Enter]** (✓) to commit the patch number selection.
- 6: Press **[Enter]** (✓) a second time to advance to the **Univ** column.
- 7: Use the keypad or the up and down arrows to enter the desired sACN universe.
Only sACN universes that have been configured can be entered. If the number of a non-configured universe is entered, the panel will reject the value and automatically revert to the previous setting. For more information on configuring sACN universes, see [sACN Universes](#) on [page 26](#).

Emergency Setup

- Emergency Outputs: Allows you to assign each position to be either “On” or off “--” when the panic input is active.
- Emergency Level: The value that the emergency circuits will activate to when the emergency input is active. Can be set anywhere between 1%–100%. The default is 100%.
- Load Shedding: Determines what occurs to the loads in the rack that are not part of the recorded emergency look. Available options include On or Off, with a default of On.
 - When set to Off, the circuits will remain at their last control level at the time of emergency contact activation.
 - When set to On, the circuits that are included in the emergency look will turn on to the Emergency level. Any circuits that are not set to be included in the emergency look will turn off.

Emergency Setup	
Emergency Outputs:	
Emergency Level:	100%
Load Shedding:	On

Quick Rack Setup

The “Quick Rack Setup” menu offers a simple, initial setup of the panel and is available by default when the panel is otherwise un-configured.

For additional setup or to quickly change a setting after initial configuration, access “Quick Rack Setup” from the main menu.

Quick Rack Setup	
Output Count:	Auto
DMX Start Addr:	1
sACN Universe:	1
sACN Start Addr:	2
Space:	1
Apply Changes* Only	
Apply All	



CAUTION: *The “Quick Rack Setup” operation will erase your rack’s configuration and generate a new one. It is recommended to make a backup of your configuration before entering this menu option.*

- Output Count: When **Auto** is selected, the numbering and arrangement of the outputs is automatically detected by the presence or absence of breakers and relays. When a number is entered in place of **Auto**, the rack assumes that number of relays. Any output positions where relays or breakers are not detected are assumed to contain a single-pole option.
- DMX Start Address: Displays the first DMX address used for patching. The default is 1.
- sACN Universe: Displays the first sACN universe in the panel (1–63999).
- sACN Start Address: Displays the first sACN address in the panel (1–512).
- Space: Determines the space to which all relays or breakers in the rack will be assigned (1–255).
- Apply Changes* Only: Only the items that have been changed shall be applied.
- Apply All: All items will be applied regardless if they have been changed or not.
 - For example, if a DMX start address of 510 is entered and **Apply All** is selected, the panel’s auto-fill feature may cause consecutive addresses to extend beyond the allowed 512. In this instance the panel will automatically unpatch all circuits with an invalid address by assigning them to DMX zero.
 - The same is true if an sACN address entry causes an address overflow. All relays or breakers holding invalid addresses will be unpatched by assigning them to zero.

Address Assignment

The Quick Rack Setup operation automatically assigns addresses to the outputs in the rack.

- In EchoDIN, numbering is sequential from left to right across the relay modules.
- In Sensor IQ, ERP-FT, and ERP, the numbering is based on a left to right (horizontal) and then down (vertical) sequence as shown below.

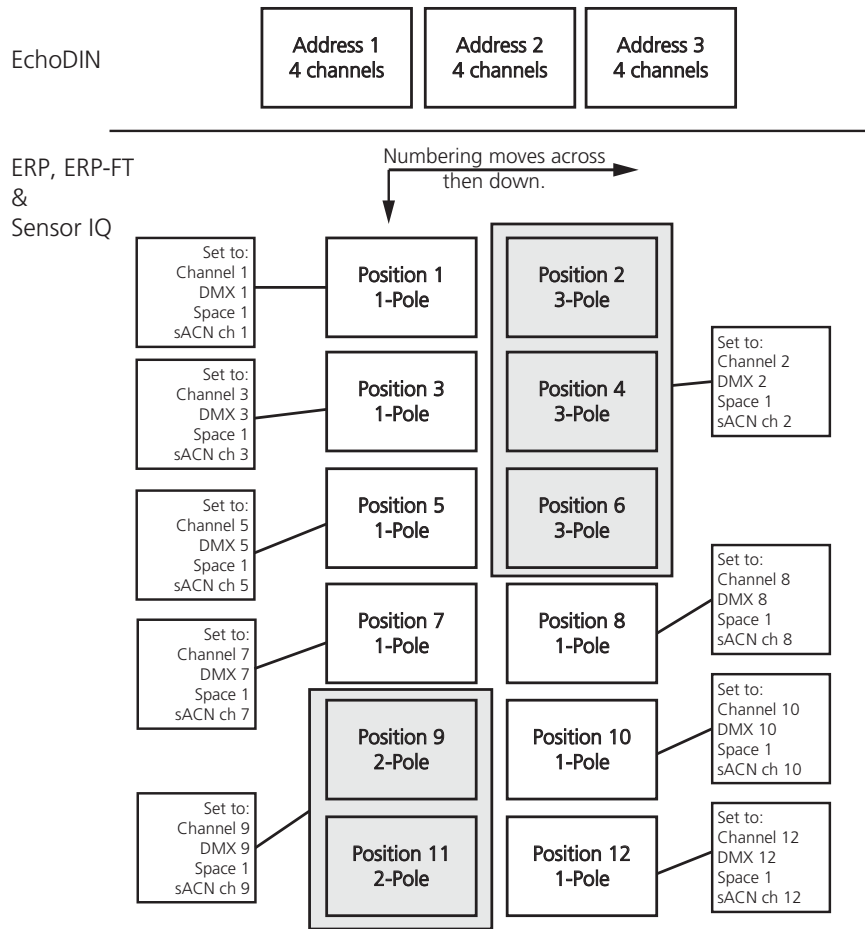

Switching Setup

This menu allows for configuration of switching delay and Latch/Lock settings.

- Switching Delay: Delay when outputs turn on, in milliseconds. Outputs turn on in sequential order within the panel.
- LatchLock On: Displays the input control level range that causes the "On Time" to start; shown in 10% ranges.
- L/L On Time: The amount of time the control level must be set before a circuit is switched on with LatchLock. Default is five seconds.
- LatchLock Off: Displays the input control level range that causes the "Off Time" to start; shown in 10% ranges.
- L/L Off Time: The length of time the control level must be set before a circuit is switched off with LatchLock. Default is five seconds.

Switching Options	
Relay Delay:	0ms
LatchLock On:	91-100%
L/L On Time:	5s
LatchLock Off:	41-50%
L/L Off Time:	5s

LatchLock Mode

LatchLock mode provides added security against incidental turn-on or turn-off of critical circuits. It requires that the control level remains in a specific range for a specific amount of time in order to switch on or off the circuit.

To illustrate this example:

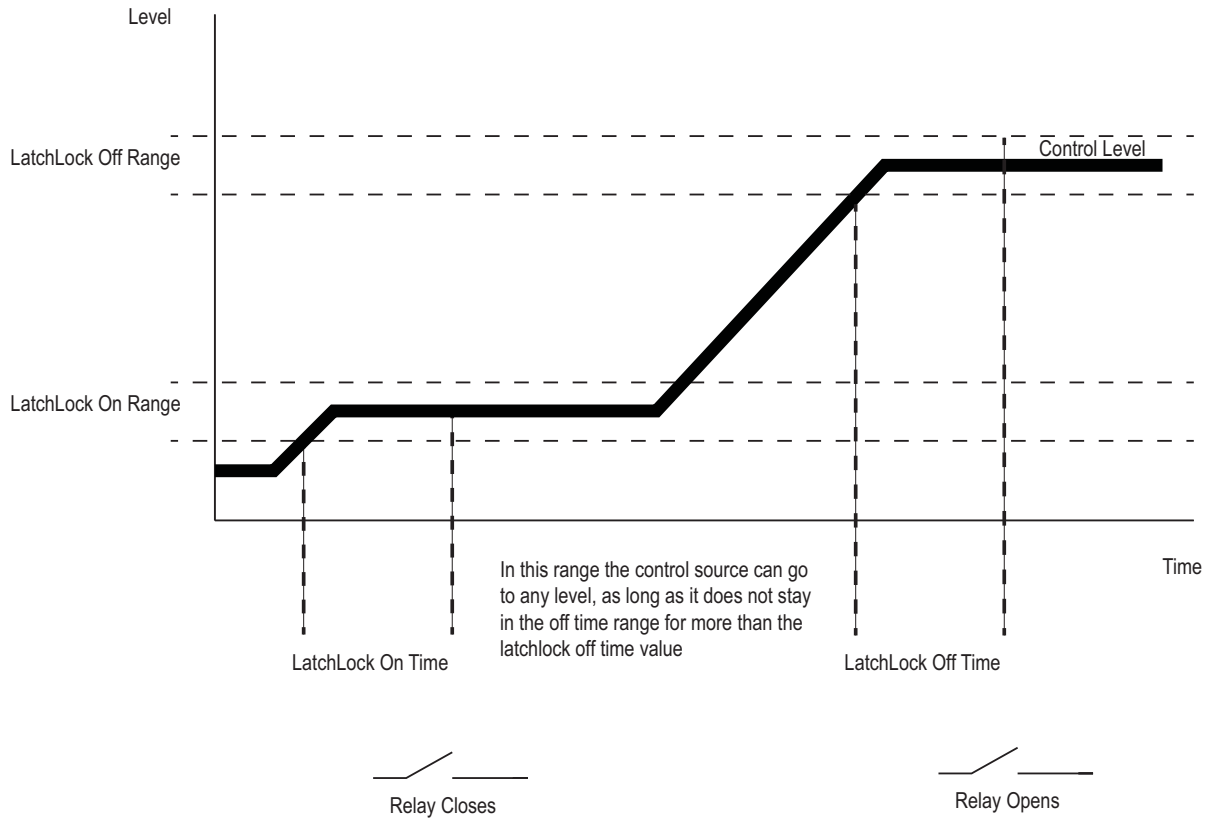

Arch Setup Menu

Station Power

Station Power determines whether or not the built-in Echo station power supply is turned on or off. Default is Off. Only one Echo station power supply should be turned on per Echo system. See [Station Control](#) on [page 9](#) for more information about station topologies.

Remote Record

Remote Record controls whether preset record is allowed from connected Echo control stations. Options include On or Off. Default is Off.

Arch Setup	
Station Power:	On
Remote Record:	On
Data Source Settings	
Data Loss & Power On	
Preferences	
Network Settings	
Contact Inputs	
Timeclock	

Data Source Settings

- DMX Input: Determines if the DMX input port to the controller is Enabled or Disabled. The default is Enabled.
- DMX Priority: Determines priority level at which the DMX input will be treated in the prioritization. See [Source Arbitration](#) on [page 10](#) for more information about source prioritization. The default value is 100.
- Arch Priority: Determines the playback priority to be used for preset, sequence, and zone activations controlled by the connected Preset Stations. The last action takes precedence. See [Source Arbitration](#) on [page 10](#) for more information about source prioritization. The default value is 100.
- Contact Priority: Determines the priority of the contact input source. The range can be set from 1–201 with a default of 100.
- Packet Delay: Allows the controller to manage the number of times a DMX value must be present before acknowledging and reacting to that value. With the default setting of “0”, the panel will react the first time it receives a valid DMX command. With the max setting of “10”, the panel will react after receiving the same DMX command ten times.



Note: DMX refreshes approximately 40 times per second.

Data Loss & Power On

- Data Loss Settings: This selection displays a sub-menu that allows configuration of the DMX Loss Behavior, sACN Loss Behavior, and Power On Behaviors.

DMX Loss Behavior	
Mode:	Wait and Fade
Wait Time:	3min 0sec
Fade Time:	0min 3sec
sACN Loss Behavior	
Mode:	Hold Last Look
Wait Time:	Forever
Power On Behavior	
Power On:	Last-Look

- Mode: may be set to “Wait and Fade”, or “Hold Last Look”. Loss behavior defaults to “Hold Last Look”.
 - Hold Last Look: Holds any active dimmers at whatever levels they were receiving prior to the loss of data. The last levels are retained until data is restored or another source takes control.
 - Wait and Fade: Holds the last levels received when the data was lost for a user-defined amount of time and then fades those input levels to zero intensity using a user-defined fade time. The default wait time setting is three minutes and zero seconds. The default fade time setting is three seconds.

- Wait Time: Determine the wait time in minutes and seconds if the mode is set to “Wait and Fade”. Range is from 0–59 minutes and 0–59 seconds. The default wait time is 3 minutes, 0 seconds. If the mode is set to “Hold Last Look”, the time displays as “Forever” and cannot be modified.
- Fade Time: Determine the fade time in minutes and seconds. Range is from 0–59 minutes and 0–59 seconds. The default is 3 seconds.

- Power On Behavior: Determine the behavior for the control when the Power Control Processor powers on. Options include "Last-Look" and "Off". The default is "Last-Look".
 - Last-Look: Relays remain in their positions from the last power cycle, when the controller was powered up, if there is no control source.
 - Off: Relays go to Off when the controller is powered up, if there is no active control source for DMX or sACN.

Preferences

- Backlight Mode: The backlight has three possible modes of operation including Auto, On, or Off. The default is Auto.
 - Auto: Keeps the display backlight illuminated after boot-up and after last button push for a specified amount of time.
 - On: Keeps the display backlight illuminated at all times.
 - Off: Turns off the backlight illumination.
- Backlight Time: Controls the length of time before the backlight turns off when in Auto mode. The default is 3 minutes; it can be set from 0:10 sec to 9:59 min.
- Contrast: Contrast settings can be set from 1–100 from this screen or the home screen.
- Language: Default setting is English.

Preferences	
Backlight Mode:	Auto
Backlight Time:	3:00
Contrast:	100
Language:	English

Network Settings

Network Setup provides editing and setup related to the Ethernet Interface card including IP address configuration, sACN universe setup, and web UI enable and disable.

IP Address

IP Address allows editing and setup of the network properties of the Ethernet Interface card. Two options are available (Automatic and Manual). Default is Automatic.

- Automatic: The Ethernet Interface option will attempt to acquire an address from an Address (DHCP) server on the network. If a DHCP server is not found, the card will default to a Link Local address for the current power cycle.
- Manual: manual entry of an IP address, Subnet Mask, and Gateway are allowed. The default IP and Gateway addresses will be 10.101.1.1. The default Subnet Mask will be 255.255.0.0.

IP Address	
Type:	Manual
IP:	10.101.165.101
Mask:	255.255.0.0
Gway:	10.101.165.101
Apply and Exit	
MAC:	00:c0:16:aa:bb:c

sACN Universes

Allows configuration of the sACN universes that are available for patching. The Ethernet Interface card supports up to four sACN universes.

Each universe must be set to a valid sACN universe number between 1 and 63999 or zero (entered as 0, but shown as -), to indicate that universe is unused.

When a value is changed, any output currently set to that universe will be reconfigured to the new universe.

sACN Universes	
Universe A:	63999
Universe B:	12
Universe C:	233
Universe D:	-

Web Interface

"On" enables the web UI and "Off" disables the web UI. When the web UI is disabled, it can only be enabled from the Power Control Processor user interface. See [Web UI](#) on [page 51](#).



CAUTION: *Setting Web Interface to "Off" will disable the ability to remotely configure the device from Net3 Concert.*

Contact Input

There are 24 contact inputs available in the panel. These inputs can be configured for one of several actions.

- Contact: Displays the number of contact being configured, 1–24.
- Evaluate on boot: Determines whether the contact state is evaluated on boot and the action configured for it is taken at the time of boot.
- Space: Determines the space in which the selected action will happen.
- On Open: Determine the action that occurs when the contact is opened. The following options are available:
 - None: No action will be taken when the contact opens.
 - Off: Off will be activated in the selected space when the contact opens.
 - Preset: The selected preset will be activated in the selected space when the contact opens.
 - Sequence: The sequence will be activated in the selected space when the contact opens.
 - Output to Full: The selected output range will be driven to full when the contact opens.
 - Output to 0%: The selected output range will be driven to 0% when the contact closes.
- On Close: Determine the action that occurs when the contact is closed. The same actions are available as listed above.

Contact Input	
Contact:	1
Evaluate on boot:	No
Space:	1
On Open:	Preset
Preset:	1
On Close:	Output to FL
Outputs:	1 thru 1

Timeclock

The Timeclock allows built-in timed event control for your system.

The Timeclock includes the following features:

- 24-hour astronomical timeclock with user-configurable daylight savings time (DST).
- Recurrence settings including everyday, weekday, weekends, and day of week.
- 50 field-programmable events including preset activate, sequence, and off.
- Manual control of presets with override capability.
- Current event manual “hold” up to two hours with the option to manually cancel before those two hours expire.
- Automatic schedule resumption after a power loss.
- Holiday shut-off configuration by space.

Holds

A Hold can be triggered to override a scheduled event, preset, or sequence during normal operation. When a Hold is active, regularly scheduled events are ignored. The timeclock interacts with the presets and sequences to determine specific Hold behavior. The response differs depending on the scheduled event and the type of Hold that is currently active.

When an active Hold is cleared, the originally scheduled event is restored. Any manual control without an active Hold condition only temporarily changes the current state of the Echo system. The next event will execute according to its schedule.

Timed Hold

A Timed Hold occurs when a scheduled event is interrupted by manually triggering a preset or sequence. Set *Auto Timed Hold* within the *Schedule Events* Menu to dictate if an event responds to a manually activated preset or sequence. See [Schedule Events](#) on [page 28](#).

A Timed Hold will automatically clear after two hours (120 min).

Indefinite Hold

Indefinite Hold is enabled through the Arch Control menu. Select "Start Indefinite Hold" to start an Indefinite Hold. See [Arch Control Menu](#) on [page 32](#).

While an Indefinite Hold is running, all other scheduled events will be overridden and will not occur. The Indefinite Hold must be manually released before the schedule is reinstated.

Holiday Shut-Off

The Holiday Shut-Off feature provides an easy (CA Title 24 compliant) way to temporarily disable the timed event schedule and turn lighting off in designated spaces. Settings are available for shut-off for 1–7 days.

When "Start Holiday Shut-Off" is selected, the program begins a five minute countdown. At any time during this countdown, you may cancel the Holiday Shut-Off by pressing the **[Back]** (<) button.

After five minutes, Shut-Off plays in the specified spaces.

If manual control is initiated during Holiday Shut-Off, a Timed Hold will start to temporarily permit the manual lighting control. When the hold time expires, lights shut off in specified spaces replacing any manual control, and Holiday Shut-Off is reinstated using the time remaining.

Timeclock

Displays as either Enabled or Disabled.

Schedule Events

Allows for programming of both timed events that happen at a specific time and astronomical events that happen relative to sunrise or sunset.

- Event Number: Defaults to last known selection.
- Action: Options are Preset, Sequence, and Off.
- Space: Options are dependent on the previous Action settings and show 1–16. The default is 1.
- Preset: Also dependent on the previous Action setting, options are 1–64 with a default of "1".
- Recurrence: Options are Everyday, Weekdays, Weekends, and each day; Monday–Sunday. Default is "Everyday".
- When: Opens a new menu screen where you can select one of the following; Time of day, Before Sunrise, After Sunrise, Before Sunset, After Sunset, At Open Time, or At Close Time.
- Time: Allows you to enter hh:mm am/pm with a default of 12:00 am. Options are dependent on the settings in the When menu.
- Auto Timed Hold: Indicates if a timed hold has been programmed.

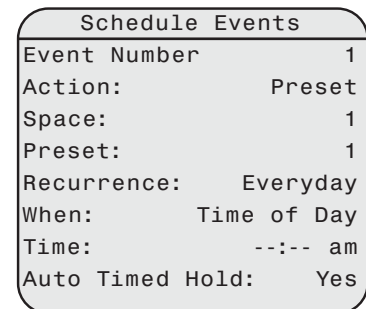
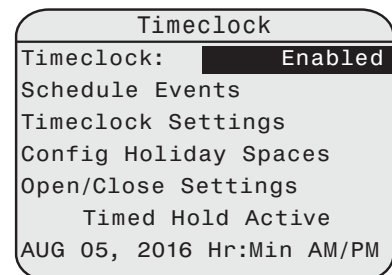

Timeclock Settings

- Time: AM and PM will only be shown when in 24-hour mode.
- Time Style: Options are 12 hour or 24 hour
- Date: Enter as MM/DD/YYYY.
- Hold Time: Enter in minutes from 30–360. The default is 120 minutes.
- Flick Warn: Options are Yes or No. Yes is the default.
- Warn Time: Options are 1–60 minutes with 2 minutes as the default.
- Time Zone: GMT -12 through +13 are the options with a default of -6.
- Latitude: Use the keypad to enter, system defaults to N (north)
- Longitude: Use the keypad to enter, system defaults to W (west)
- DST: Options include None, Manual, EU, or US, with US as the default.
- Manual DST Dates: Additional menu options allow you to manually enter the month, day, and occurrence of daylight savings/standard time. For more details, see [Menu Flow Chart](#) on [page 38](#).

Timeclock Settings	
Time:	3:45PM
Time Style:	24 Hour
Date:	Jun/07/2014
Hold Time:	120 min
Flick Warn:	Yes
Warn Time:	2 min
Time Zone:	GMT-6
Latitude:	43 8 N
Longitude:	89 20 W
DST:	US
Manual DST Dates	



Note: For Times, Date, Latitude, and Longitude fields, using the [Back] (<) button will automatically discard all edits.

Config Holiday Spaces

All spaces default to “Shut-Off” but can be individually configured to be unaffected. Spaces that are configured to “Shut-Off” will not execute any presets, sequences, or timed events normally scheduled for the space.

Spaces set to “Unaffected” will continue to allow normally scheduled events and remain unaffected by a Shut-Off in other spaces.

To change the configuration for a space:

- 1: Navigate to the “Config Holiday Spaces” menu.
- 2: Press [Enter]. The spaces configured to the system will display along with their Shut-Off status.
- 3: Scroll through the menu using [Up] and [Down] to select the space to be changed.
- 4: Press [Enter] to Select the space.
- 5: Use [Up] and [Down] to choose the option required for the space, either “Unaffected” or “Shut-Off.”
- 6: Press [Enter] to commit the selection.
- 7: Repeat steps for all required spaces.

Config Holiday Spaces	
Space 1:	Shut-Off
Space 2:	Shut-Off
Space 3:	Shut-Off
Space 4:	Shut-Off
Space 5:	Unaffected
Space 6:	Shut-Off
Space 7:	Shut-Off
Space 8:	Shut-Off



Note: For examples of timed event programming, see [Timeclock](#) on [page 45](#).

Open/Close Settings

The Open/Close settings allow you to program the timeclock to have a master Open and Close time that will be available to all scheduled events.

- 1: Navigate to Open/Close Settings and press **[Enter]** (✓). The headings of Weekdays, Saturday, and Sunday cannot be modified.
- 2: Press **[Enter]** (✓) once to navigate to the Time field. Each subsequent press of **[Enter]** (✓) commits the current selection and progresses to the next available selection field. Pressing **[Back]** (←) discards any changes and highlights the previous selection.
 - The default value for Open is 8:00 a.m.
 - The default value for Close is 9:00 p.m.

Switching Control Menu

The Switching Control menu is provided to set output levels, check outputs, and release any set output levels. Direct access to the "Switching Control" menu is also available by pressing the **[Control]** (⌘) button on the user interface.

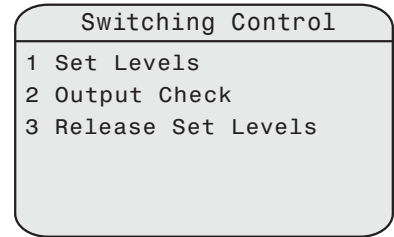

Set Levels

The Set Levels menu option allows you to select circuits by slot number and manually set them to a level. All configured relays/breakers are listed.

- NA indicates a position that is either part of a 2-pole or 3-pole relay, or where no relay exists.
- "—" indicates the dimmer is released from or is not under Set Level control.

To set output levels:

- 1: Use the numeric keypad including the **[and]** and **[thru]** buttons to specify a circuit, or range of circuits.
- 2: Press **[Enter]** (✓) to accept the selection.
- 3: You will now be in the value field. Type in a level value.
- 4: Press **[Enter]** (✓) to apply that level or **[Back]** (←) to discard it.

When you exit the "Set Levels" menu option, you will be prompted for confirmation of whether you would like to "Release Set Levels".

- Selecting "Yes" returns all set levels to the default value.
- Selecting "No" causes all set levels to remain until released.

Output Check

The Output Check menu option allows for checking outputs individually.

- Output: Defaults to position "1". It is then possible to scroll through all outputs to perform a quick functionality check. Output position numbers will roll over from one to the maximum, and vice versa.
- Check Level: Use this field to set the percentage that each position will be driven to during a output check.
- Next Output: Select to advance to the next position during an output check.
- Previous Output: Select to move to previous position during an output check.

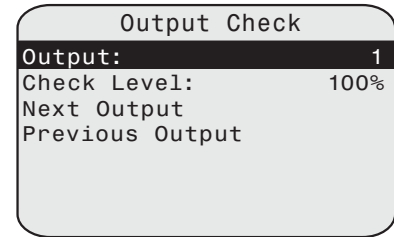

Output control is released when you exit the "Output Check" menu.

Release Set Levels

Use this menu to release all set levels. After one second, this screen will return to the "Switching Control" menu.



Note: *While in Output Check or Set Levels menus, the time-out period, which reverts to the home screen, does not apply. This menu will remain visible until further user interaction.*

Arch Control Menu

The “Arch Control” menu provides you access to the setup and timing of the control system presets and sequences.

Arch Control	
1	Presets
2	Sequences
3	Start Timed Hold
4	Start Holiday Shutoff
5	Start Indefinite Hold

Presets

Presets	
Space:	1
Preset 12 Active	
Preset#:	2
Activate	
Record	
Fade Time:	0min 2sec

The “Presets” menu provides you with the tools to select, activate, deactivate, record, and configure presets.

- Space: Determine the space to which the entered preset numbers apply. Your available choices will depend on the configured spaces within the rack.
 - The second line in the screen shows status of the currently active preset for the selected space, or “No Active Preset” if no presets are currently active.
- Preset: Select the preset within the space you want to work with. Each space contains presets numbered between 1 and 64.
 - Activate/Deactivate:
 - When the current selected preset is NOT active, “Activate” will be displayed for selection. With “Activate” selected, pressing **[Enter]** (✓) activates the current selected preset. Any other presets playing in the space will be deactivated.
 - When Deactivate is selected, pressing **[Enter]** (✓) deactivates the current selected preset.
 - Record: Pressing **[Enter]** (✓) records the current selected preset using the current levels of all of the circuits within the selected space. Levels can be DMX, sACN, manually set levels from the user interface, or a combination of sources.
 - Fade Time: Determines the length of time it will take for a preset to fade up and down.

Sequences

The “Sequence” menu provides you with the tools to start and stop a sequence, edit the steps of a sequence, and configure the sequence mode.

Sequences	
Space:	1
Sequence Inactive	
Start	
Seq Mode:	Single
Edit Steps	

- Space: Select the space to which the selected sequence applies. Your available choices will depend on the configured spaces within the rack.
- Sequence # Active or Sequence Inactive: Displays the status of the sequence within the space.
- Start/Stop or Activate/Deactivate: Start or stop the sequence when the “Seq Mode” is “Single” or “Loop”. When the “Seq Mode” is set to “Bounce”, this setting changes to Activate / Deactivate.
- Seq Mode: Determine the sequence mode by selecting “Bounce”, “Single”, or “Loop”.
 - Bounce Mode is similar to a preset; it can be “Activated” or “Deactivated”. When it is activated, it runs through the sequence steps in order of recorded presets for the space, similar to a fade up. When it is deactivated, it runs through those steps in reverse order, similar to a fade down. A “Bounce” sequence is useful for powering on and off equipment that needs to be turned on or off in a particular order, like sound amplifiers and mixers.

The following example shows the activation and deactivation of a bounce sequence with three steps. The default fade time for sequences is zero seconds, so by default the panel will "snap" through these steps.

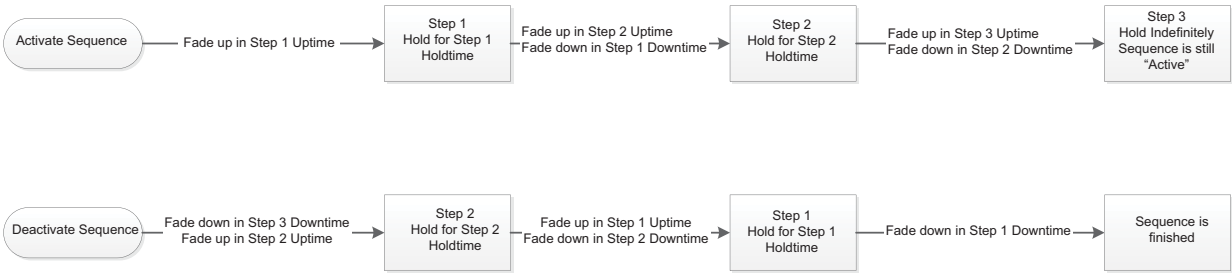

- Single Mode sequences run from beginning to end and then terminate. A Single sequence is activated by a "Start" command.

The following example shows the activation of a sequence in single mode with three steps. The sequence runs through all of the steps and then terminates.

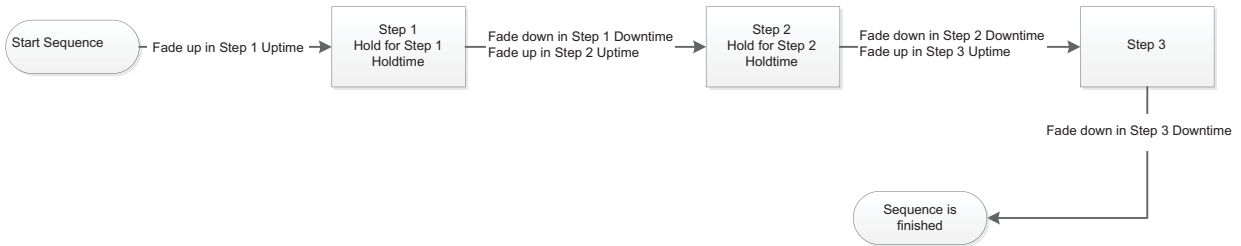

- Loop Mode sequences run the sequence steps in a loop from 1 through the highest programmed step, then starting over with 1. For example, if there are 3 steps in a sequence, the steps will be run: 1, 2, 3, 1, 2, 3, 1, 2, 3, etc.

The following example shows the activation and deactivation of a sequence in loop mode with three steps. When activated the sequence keeps running until it is deactivated.

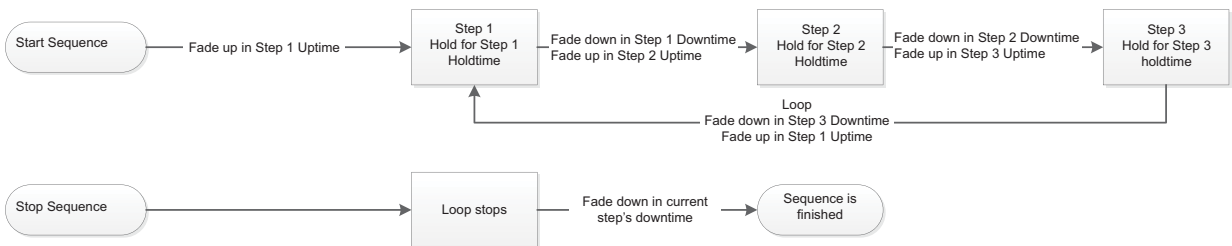

- Edit Steps: Allows you to snapshot sequence steps using the current output levels of the panel, and to alter the sequence timing and add or remove steps. You must have at least one step in a sequence.
 - Step: Scroll through each existing step in the sequence. Select the step to edit.
 - Fade Time: Determines the fade time for a step in seconds. At zero seconds, the step will “snap” with no fade time. Zero is the default.
 - Hold Time: Determines the length of time between the activation of one step and the activation of a consecutive step.
 - Record: Record the current state of the panel output into the currently selected step.
 - Insert Step After: Add another step into the sequence after the currently selected step.
 - Delete Step: Deletes the currently selected step and shifts all subsequent steps by one to close the gap.

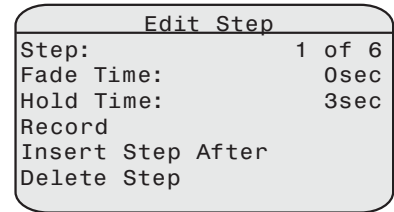

Start Timed Hold

This line indicates if any timed holds are active. The options are “Timed Hold Active”, “Holiday Shut-off”, and “Indefinite Hold”. See [Holds](#) on [page 27](#) for more information.

Auto Timed Hold

All events default to Auto Timed Hold: “Yes”. When a preset or sequence is manually triggered during an event with Auto Timed Hold set to “Yes”, that active event is placed on hold until the interrupting action has completed (default of 120 minutes). Once the interrupting action has completed, the current scheduled event is allowed to execute.

When a preset or sequence is manually triggered during an event with Auto Timed Hold set to “No”, that active event is not put on hold; it is instead overridden by the most recent action.

Scheduled events are automatically reinstated after a period of inactivity or no new manual control.

Start Holiday Shut-Off

This feature takes precedence over all other preexisting hold-conditions and starts a timed system hold from 1–7 days. Within the Holiday Shut-Off menu, once you select Start Shut-Off, you will have five minutes to enter the length of the hold. During this five-minute period, you can cancel out of the menu by pressing the **[Back]** (<) button.

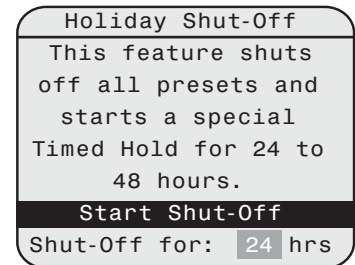

- To start Holiday Shut-Off, press **[Enter]** (✓).
- Press **[Down]** ↓ to navigate to the time field, and then using the numeric key pad, enter a length of time in hours. Once you select Start Shut-Off, you will have five minutes before the Holiday Shut-Off begins.

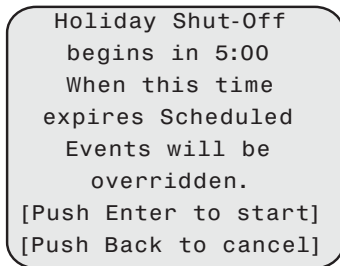

Note: Once active, the Holiday Shut-Off timer cannot be reset.

Start Indefinite Hold

This is an override function allowing a manual hold of all scheduled events. It is possible to select “End Hold” to restore the scheduled programmed event. See [Holds](#) on [page 27](#).

File Operations

The “File Operations” menu provides tools to save and load a configuration file, update firmware, and restore factory defaults.

Operations from this menu provide operations for saving and loading of files using removable USB media.

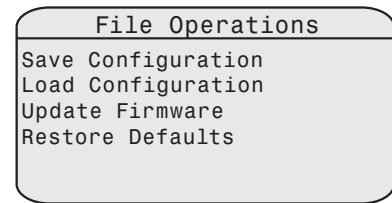

Save Configuration

Saving a panel configuration creates a file for storage to the root directory of a connected USB storage device.

- 1: Insert a USB storage device in the USB port on the front-left side of the Power Control Processor user interface. The USB device must be compatible with the Power Control Processor. See [Compatible USB Storage Device](#) on [page 14](#) for information.
- 2: Press **[Enter]** (✓) to access the main menu.
- 3: Scroll to “File Operations” and press **[Enter]** (✓) to select. The “File Operations” menu displays.
- 4: Use the **[Up]** ↑ or **[Down]** ↓ buttons to scroll to and select “Save Configuration”.
- 5: Press **[Enter]** (✓). The “Save Configuration” screen displays and the default “Filename: Echo1” is selected. You can save your file under a name between Echo1 and Echo16.
- 6: To select a different filename, press **[Enter]** (✓). The selection will focus on “Echo#”.
- 7: Use the **[Up]** ↑ or **[Down]** ↓ buttons to scroll through the list, and press **[Enter]** (✓) to make the selection.
- 8: Scroll to “Save to USB key” and press **[Enter]** (✓). The dialog will display “Saving to USB”. The file will always be saved to the root directory of the USB device.

Load Configuration

Loading a panel configuration file replaces all existing configuration data (circuit assignment, presets, sequences, and patching) with the new configuration. Before loading a new configuration onto the Power Control Processor, it is recommended that you save the existing configuration file. See [Save Configuration](#) on [page 35](#).

- 1: Insert a USB storage device in the USB port on the front left side of the Power Control Processor user interface. The USB device must be compatible with the Power Control Processor. See [Compatible USB Storage Device](#) on [page 14](#) for information.
- 2: Press **[Enter]** (✓) to access the main menu.
- 3: Scroll to “File Operations” and press **[Enter]** (✓) to select. The “File Operations” menu displays.
- 4: Use the **[Up]** ↑ or **[Down]** ↓ buttons to scroll to and select “Load Configuration”.
- 5: Press **[Enter]** (✓) to select “Load from USB Key”.
- 6: Use the **[Up]** ↑ or **[Down]** ↓ buttons to scroll through the USB directories. Configuration files are named “Echo#.CFG” (the # could be any number from 1–16). You can descend into other directories on the USB by scrolling to the name of the directory and pressing **[Enter]** (✓). You can return from directories by selecting the “..” entry in a subdirectory location.
- 7: When the configuration file to be loaded is selected, press **[Enter]** (✓). The dialog will display “Loading Configuration”.

Update Firmware

The firmware of your Power Control Processor can be field-upgraded as needed. When new firmware is released, ETC Technical Services can supply the necessary files.

Firmware is distributed as a single file with the extension “.EFW”. This file contains all firmware that is required for the controller as well as any installed option cards.



CAUTION: *Upgrading firmware may cause outputs to change. Only perform firmware upgrades when it is acceptable for output levels to turn on or off. Interrupting power during firmware upgrade may render the panel inoperable.*

- 1: Place the firmware file on the root directory of a USB storage device. The USB device must be compatible with the Power Control Processor. See [Compatible USB Storage Device](#) on [page 14](#) for information.
- 2: Insert the USB storage device in the USB port on the front-left side of the Power Control Processor user interface.
- 3: Press **[Enter]** (✓) to access the main menu.
- 4: Scroll to “File Operations” and press **[Enter]** (✓) to select. The “File Operations” menu displays.
- 5: Scroll to and select “Update Firmware”.
- 6: Press **[Enter]** (✓) to select “Load from USB Key”.
- 7: Firmware file extensions are “.EFW”. Use the **[Up]** ↑ or **[Down]** ↓ buttons to scroll through the USB directories. You can descend into other directories on the USB by scrolling to the name of the directory and pressing **[Enter]** (✓). You can return from directories by selecting the “..” entry in a subdirectory location.
- 8: When the firmware file to be installed is selected, press **[Enter]** (✓). A dialog will display a message confirming your intent to upgrade.
- 9: Select “OK” or “Cancel”. The controller will reboot and begin loading the firmware, displaying progress for each part of the update.



Note: *Do not turn off power to the controller during the firmware update process.*

Restore Defaults

To reset the Power Control Processor to factory defaults, removing all configured settings, select “Restore Defaults” from the File Operations menu. A dialog will display asking for confirmation “All settings in memory will be lost! Are you sure?”. Select “Yes” to confirm or “No” to cancel.

View Errors

This non-editable menu allows you to scroll through a list of existing errors in the rack. See Status Messages table on [page 13](#) for a list of possible error types. Errors associated with a specific position in the rack will list the position number after the error.

Chapter 3

Service and Maintenance

Service

Contacting ETC about equipment problems

If you are having difficulties, your most convenient resources are the references provided in this manual. To search more widely try the ETC web site at etconnect.com. If none of these resources is sufficient, contact ETC technical services directly at one of the offices listed on [page 1](#).

Emergency service is available from all ETC offices outside of normal business hours. When calling for assistance, please have the following information handy:

- Your location and job name.
- Model of relay or breaker panel(s).
- Type of relays and breakers used including model number and quantity.
- Other components in your system including dimmers, switch gear, quantity and type of wall stations, etc.
- DMX and/or sACN control source used for system-wide control, if any.
- Related system problems or equipment failure.

Maintenance

Vacuum the Interior



WARNING: RISK OF DEATH BY ELECTRIC SHOCK! Failure to disconnect all power to the panel before working inside the panel could result in serious injury or death.

De-energize main feed to the panel and follow appropriate Lockout/Tagout procedures as described in NFPA Standard 70E. It is important to note that electrical equipment such as relay and breaker panels can present an arc flash safety hazard if improperly serviced. This is due to available large short circuit currents on the feeders of the equipment. Any work on energized equipment must comply with OSHA Electrical Safe Working Practices.

- 1: Remove power from the panel.
- 2: Remove any doors, top, and bottom front panels from the rack.
- 3: Vacuum the dust from the interior of the unit. If needed, use canned air to blow dust from the relay or breaker panels.
- 4: Reinstall the front panels and door before applying power to the unit.

Changing Fuses

The Echo Relay Panel Mains Feed features internal fuses on the relay cards to protect the relay in the event of a high current short circuit. Most faults should cause the associated circuit breaker to trip; however, very high current direct shorts may cause fuse failure also.

Two spare fuses are included inside the panel. The fuse is a 30A SC-30 and is available from ETC with part number F334. Replace the fuse with the same type only.

Appendix A

Menu Flow Chart

This appendix contains the Echo Relay Panel menu structure.

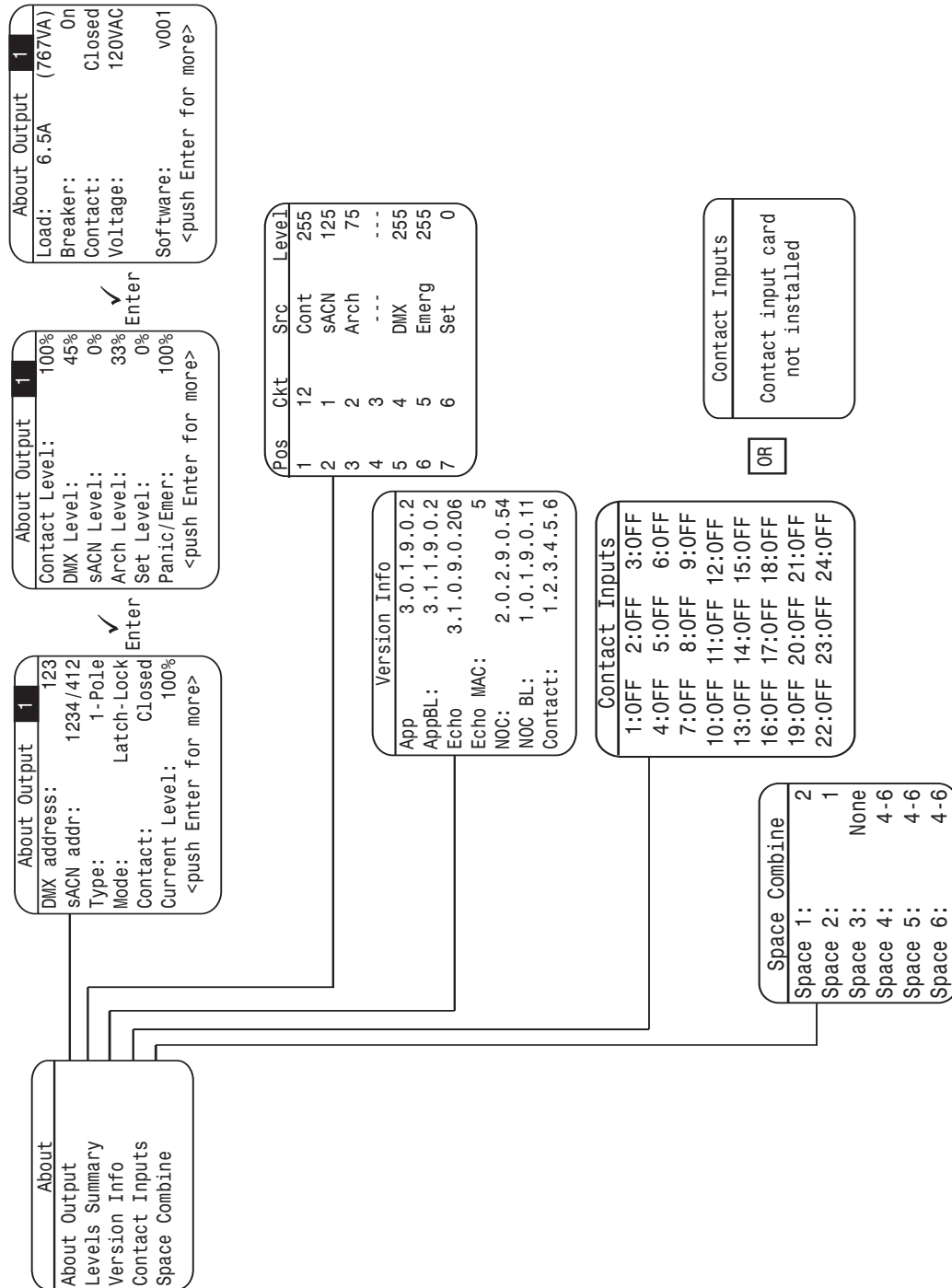

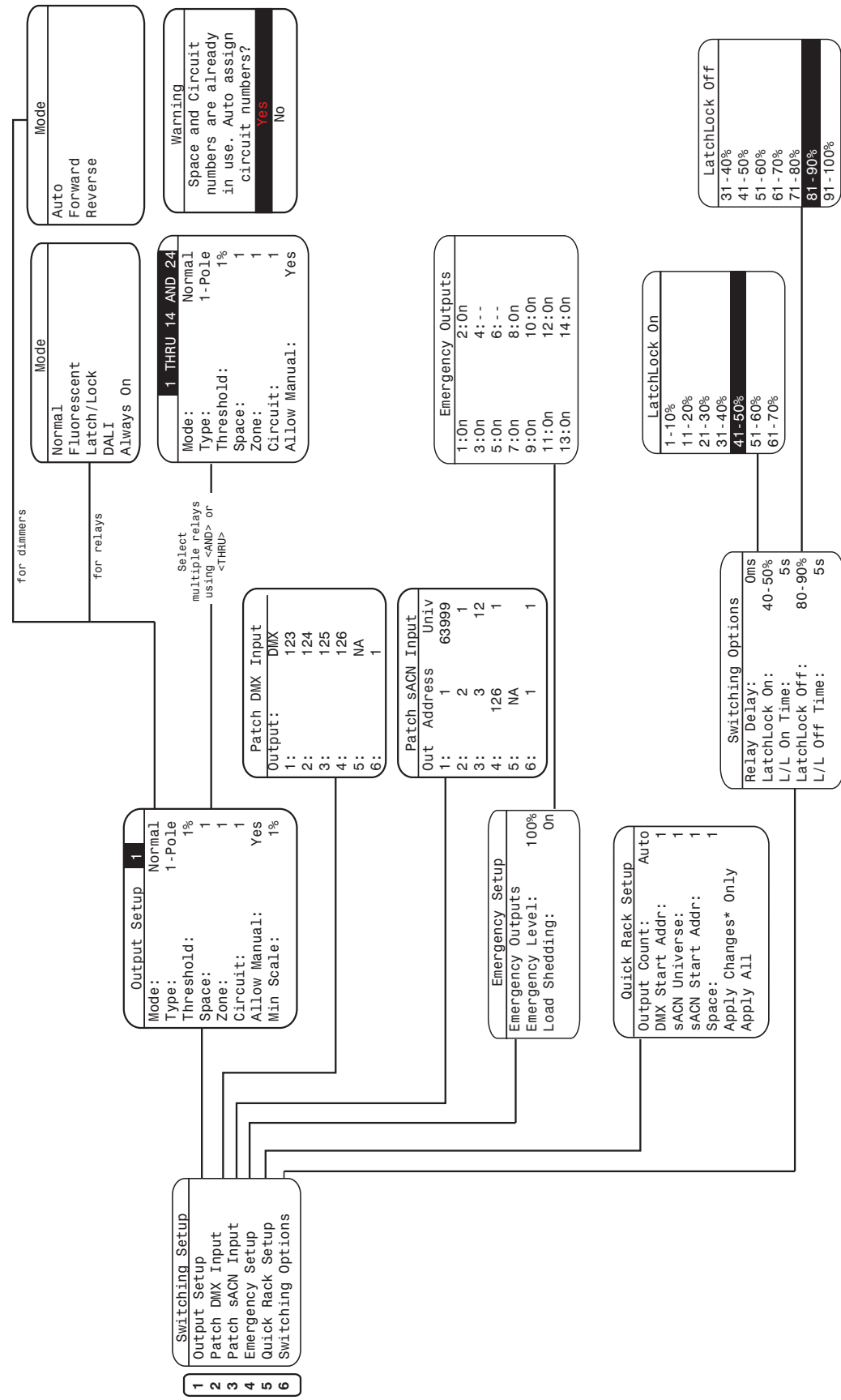

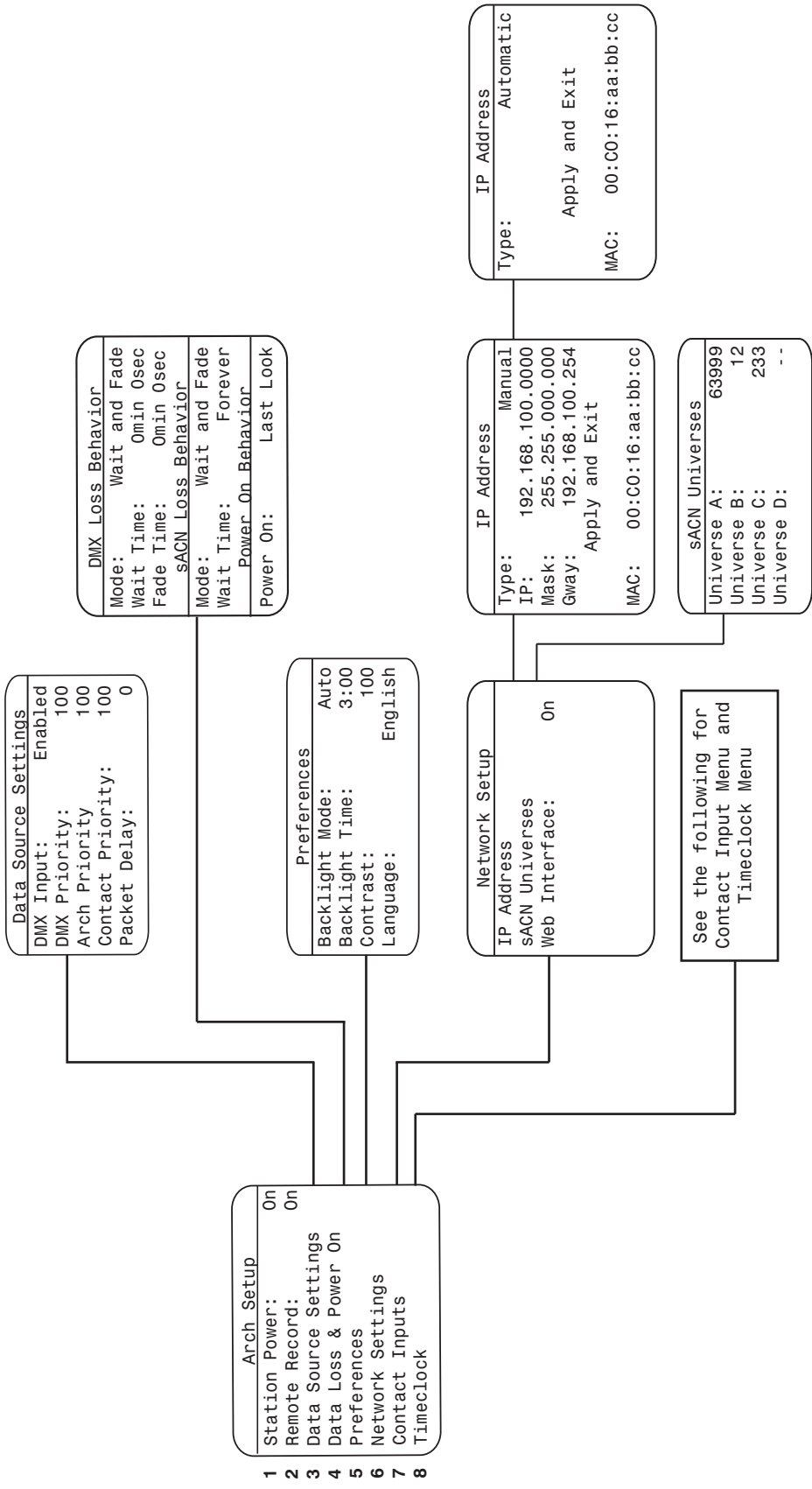

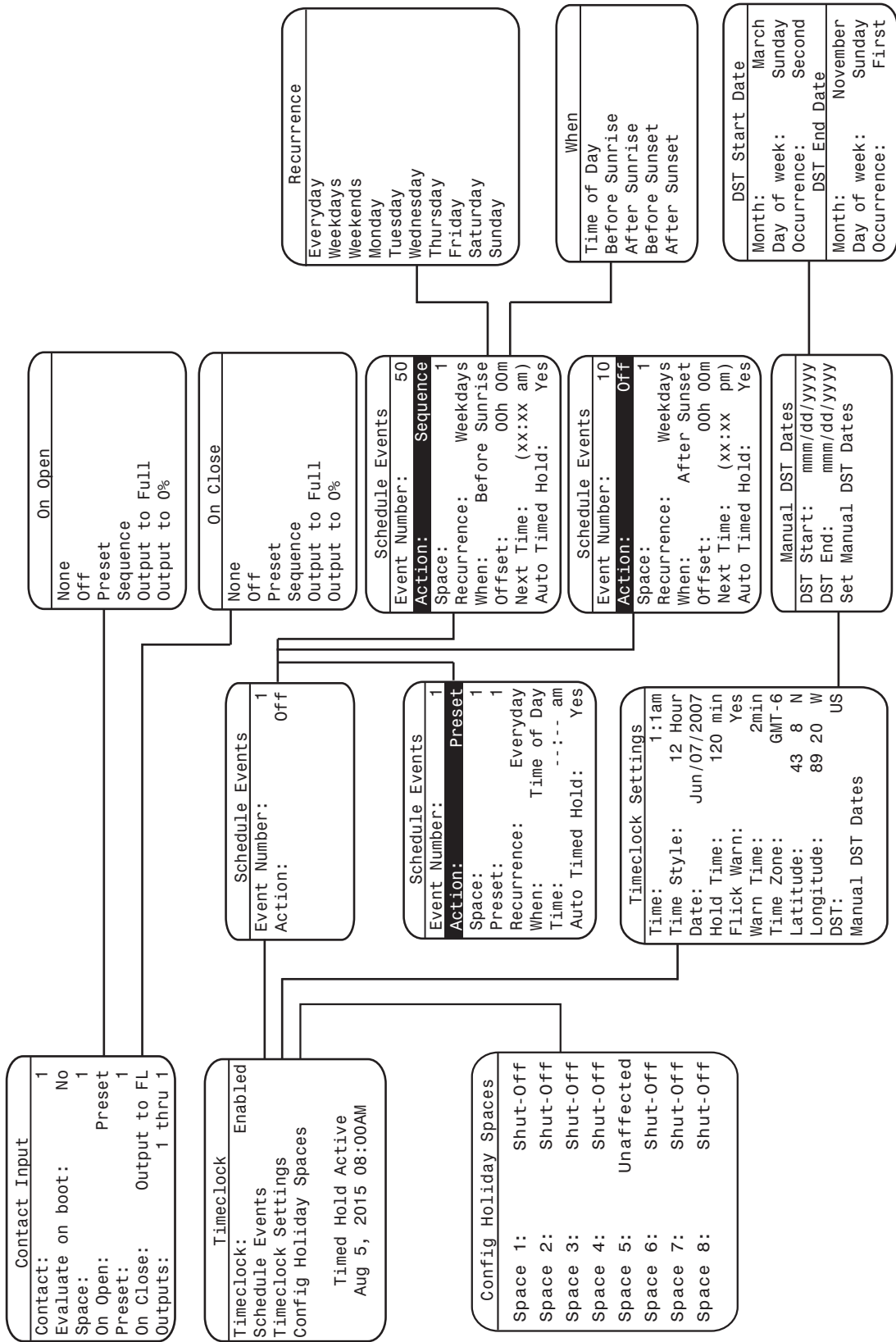

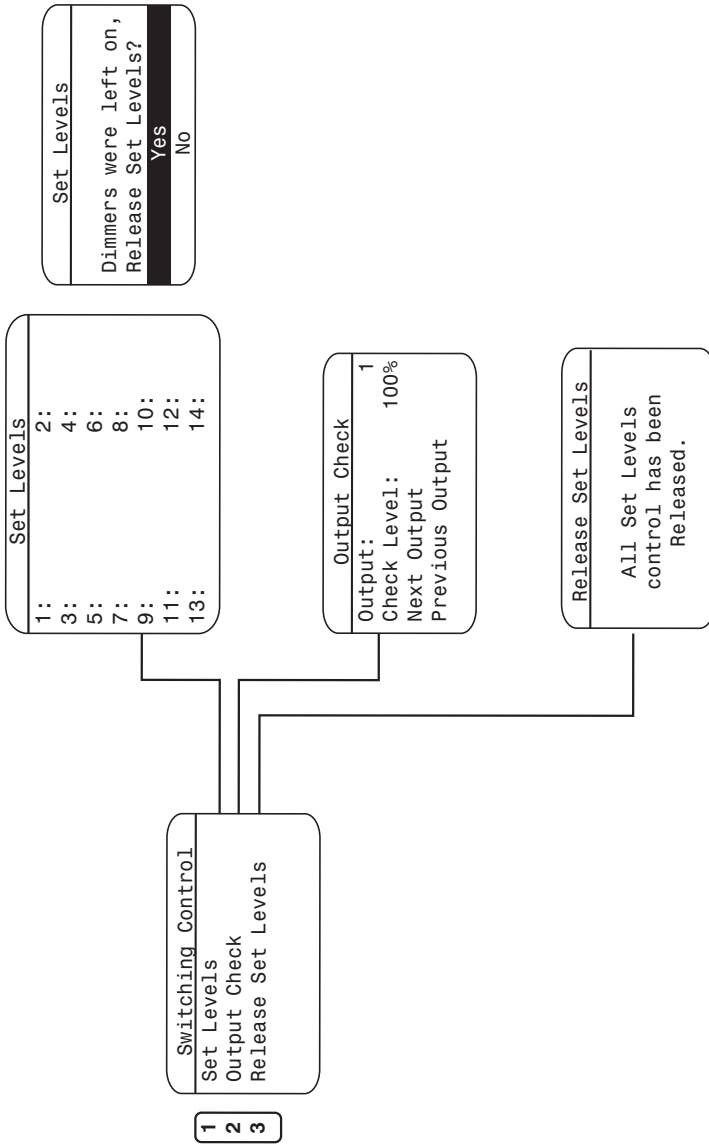

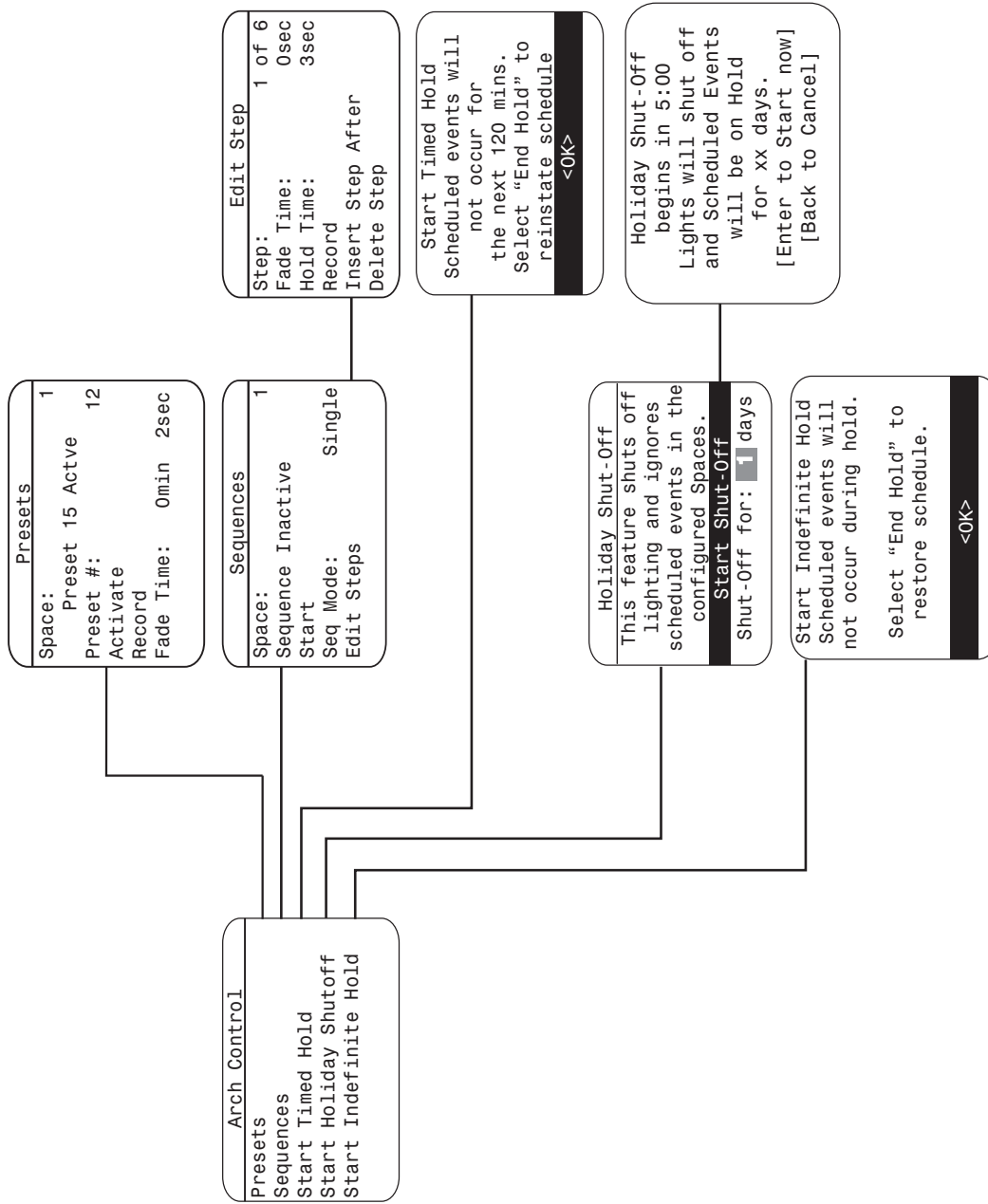

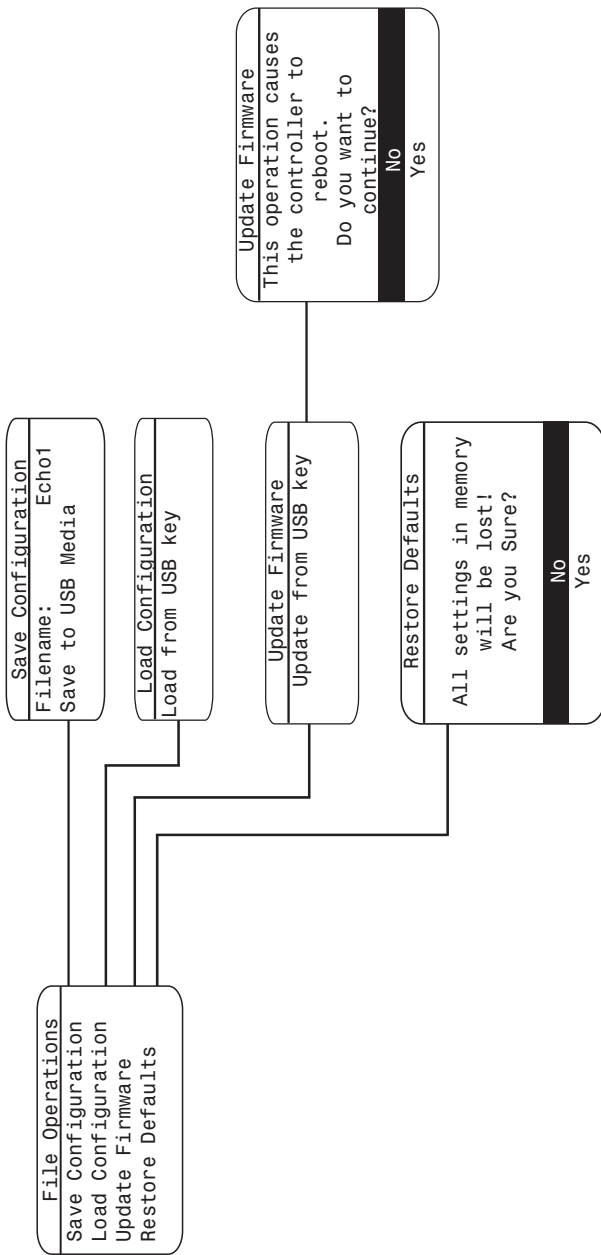

Appendix B

Timeclock

Programming examples

The following pages contain step by step instruction on programming common system timed events.

Astronomical event

An astronomical event is based on the sunrise and sunset. This example describes how to turn on lights 30 minutes before sunset and turn them off again at sunrise.

- 1: Within the Arch Setup menu, select the Timeclock menu, and make sure **Timeclock** is set to "Enabled".
- 2: Press **[Down]** ↓ to advance to the **Schedule Events** option.
- 3: Press **[Enter]** ✓ and advance to the "Event Number" selection. Use the numeric keypad or the **[Up]** ↑ or **[Down]** ↓ buttons to enter the event number. For this example, the event number is "1".
- 4: Using the same menu selection techniques, set the following options:
 - The "Next Time" field auto-populates based on the settings programmed within the Timeclock Settings menu.
 - See [Menu Flow Chart](#) on [page 38](#) for the full menu flow.

As soon as you exit this **Schedule Events** menu, this astronomical event will be active indefinitely.

Schedule Events	
Event Number:	1
Action:	Preset
Space:	1
Preset:	1
Recurrence:	Everyday
When:	Before Sunrise
Time:	0h30m
Next Time:	(5:56am)

Timed event

A timed event is based on a specific time of day. This example describes how to turn on lights at 7:00 a.m. and then turn off lights at 5:00 p.m.

- 1: Within the Arch Setup menu, select the Timeclock menu, and make sure **Timeclock** is set to "Enabled".
- 2: Press **[Down]** ↓ to advance to the **Schedule Events** option.
- 3: Press **[Enter]** ✓ and advance to the "Event Number" selection. Use the numeric keypad or the **[Up]** ↑ or **[Down]** ↓ buttons to enter the event number. For this example, the event number is "2".
- 4: Press **[Enter]** ✓ to commit the selection.
- 5: Press **[Down]** ↓ to navigate to **Action**. The options for this line include *Preset*, *Sequence*, and *None*. For this example select *Preset*.
- 6: Press **[Enter]** ✓ to commit the selection.
- 7: Using the same menu selection techniques, set the options shown to the right.

Schedule Events	
Event Number:	2
Action:	Preset
Space:	1
Preset:	1
Recurrence:	Monday
When:	Time of Day
Time:	5:00pm

To activate the timed event:

- 1: Navigate to the Arch Control menu.
- 2: Select the Presets menu.
- 3: Scroll to Preset # and select the event preset number, (in this example we use #2).
- 4: Scroll down one more line to **Activate** and press **[Enter]** ✓.

Your Timed Event will now activate preset #1 every Monday at 5:00 p.m. until manually modified.

See [Menu Flow Chart](#) on [page 38](#) for the full menu flow.

Holiday shut-off

A holiday shut-off is programmed to temporarily deactivate all presets and sequences set to run during normal operation. A Holiday Shut-off can be programmed to run for 1–7 days.

- 1: Navigate to the Arch Control menu.
- 2: Select the Start Holiday Shut-off option.
- 3: Navigate to **Shut-Off for:** line at the bottom of the screen.
- 4: Use the **[Up]** ↑ or **[Down]** ↓ buttons to select either a 24 or 48 hour run time.
- 5: Press **[Enter]** ✓.
- 6: press the **[Up]** ↑ to navigate to the Start Holiday Shut-Off command.
- 7: Press **[Enter]** ✓.

The following screen will appear asking you to confirm the start of the Holiday Shut-off.

- Pushing **[Enter]** ✓ will start the Holiday Shut-off before the five minute countdown is completed.
- Pushing **[Back]** (<) will cancel the Holiday Shut-off.

Holiday Shut-Off
begins in 5:00
When this time
expires Scheduled
Events will be
overridden.
[Push Enter to start]
[Push Back to cancel]

Appendix C

Status Messages

The Power Control Processor shows messages on the display to advise status of the system or the components in the panel itself.

Status Message	Cause	ERP	Echo-DIN	ERP-FT	Sensor IQ
System OK	No other messages active	Yes	Yes	Yes	Yes
Emergency Active	Emergency look is active	Yes	Yes	Yes	Yes
Breakers Tripped	No voltage detected at one or more relays	Yes	Yes	No	Yes
Relay Mismatch	One or more relays in the rack are mismatched	Yes	No	No	No
Relay Removed	One or more relays in the rack are not found	Yes	Yes	No	No
Breaker Mismatch	One or more breakers don't match the configuration	No	No	No	Yes
Breaker Removed	One or more breakers in the rack are missing	No	No	No	Yes
Timed Event Hold	User has applied a timed event hold.	Yes	Yes	Yes	Yes
Holiday Shut-off	User has activated Holiday Shut-off	Yes	Yes	Yes	Yes
Drive 1/2 Error	Unable to communicate to the breaker drive board	No	No	No	Yes
Breaker Error	Breaker is detected as an impossible type	No	No	No	Yes
Dim Overtemp	Dimmer is in an overtemp state	Yes	Yes	No	No

Emergency Active

Emergency contact closures are commonly used with auxiliary systems, such as fire alarms. For information on wiring and configuring the emergency input on your specific panel, see the applicable Installation Manual found on etconnect.com.

An "Emergency Active" status message on the display indicates that the emergency ("Panic") contact input has been triggered and the configured emergency look is active in the panel.

An "Emergency Active" status message is the highest priority message; no other status message displays while this status is active. In addition, this status cannot be cleared until the condition is cleared. For example, resetting the fire alarm signal would clear the condition.

Breakers Tripped

A "Breakers Tripped" message indicates that voltage is not detected at one or more relay or breaker inputs. Typically this condition is caused by one of the circuit breakers at the panel tripping or being switched off.

To resolve this message, check the circuit breakers in the panel and verify that they are all turned on. As needed, reset the breaker or determine if additional troubleshooting of the circuit is required.

To achieve short circuit ratings, the Echo Relay Panel Mains Feed has in-line fuse for each relay card. Two spare fuses are included inside the panel. The fuse is a 30A SC-30 type fuse, available from ETC with part number F334. Replace the fuse only with the same type. See [Changing Fuses](#) on [page 37](#) for information on how to replace a fuse if necessary.

Relay Mismatch

A “Relay Mismatch” message indicates that there is a difference between the type of relay in the configuration for the Power Control Processor and the type of relay (could be one or more) detected in the panel. This condition occurs when relays have been added or altered in the panel after the configuration was created.

To resolve a “Relay Mismatch” condition, reconfigure the panel using the Quick Rack Setup menu (see [page 22](#)).

Relay Removed

A “Relay Removed” message indicates that one or more relays are missing from the panel, according to the configuration of the Power Control Processor.

This condition occurs when relays have been removed from the panel after configuration., To resolve a “Relay Removed” condition, re-configure the panel using the Quick Rack Setup menu (see [page 22](#)) or replace the relay in the panel following appropriate electrical safety procedures.

When a relay has not been removed from the panel and the condition persists, additional troubleshooting is required with power removed.

Breaker Mismatch

This error message will only appear in a Sensor IQ panel. A “Breaker Mismatch” message indicates that there is a difference between the type of breaker (one or more) in the configuration and the type of breaker detected in the panel. This condition occurs when breakers have been added or altered in the panel after the configuration was created.

To resolve a “Breaker Mismatch” condition, reconfigure the panel using the Quick Rack Setup menu (see [page 22](#)).

Breaker Removed

This error message will only appear in a Sensor IQ panel. A “Breaker Removed” message indicates that one or more breakers are missing from the Sensor IQ panel, according to its configuration.

This condition occurs when breakers have been removed from the panel after configuration., To resolve a “Breaker Removed” condition, reconfigure the panel using the Quick Rack Setup menu (see [page 22](#)) or replace the breaker in the panel following appropriate electrical safety procedures.

When a breaker has not been removed from the panel and the condition persists, additional troubleshooting is required with power removed. For information on how to replace a breaker, see the *Sensor IQ Installation Manual*.

Drive 1/2 Error

This message will only appear in a Sensor IQ panel and indicates that the Power Control Processor is unable to communicate with the control boards that drive the branch breakers in the Sensor IQ system.

There are two control boards located under the circuit breakers designated as 1) the left board and 2) the right board, as viewed from standing in front of the panel and looking in.

If this message appears during commissioning:

- 1: Turn off all power to the panel.



WARNING: RISK OF DEATH BY ELECTRIC SHOCK! Failure to disconnect all power to the panel before working inside could result in serious injury or death.

De-energize main feed to the panel and follow appropriate Lockout/Tagout procedures as mandated by NFPA 70E. It is important to note that electrical equipment such as breaker panels can present an arc flash hazard if improperly serviced. This is due to the high amounts of short-circuit current available on the electrical supply to this equipment. Any work must comply with OSHA Safe Working Practices.

- 2: Once power is off, check connections between the Power Control Processor and the two boards.
 - a: Using a #2 Phillips screwdriver, remove the four screws securing the Power Control Processor to the mounting plate and set aside in a safe location. The Power Control Processor is now loose.
 - b: Push upwards on the Power Control Processor to:
 - Ensure all connectors are properly seated.
 - Ensure that the Power Control Processor is resting on the metal standoffs.

If this message appears after a period of operation:

Contact ETC technical services for assistance in troubleshooting the problem.

Breaker Error

This error message will only appear in a Sensor IQ panel and indicates that the control boards are unable to communicate with a circuit breaker.

To troubleshoot the problem:

- 1: Turn off all power to the panel.



WARNING: RISK OF DEATH BY ELECTRIC SHOCK! Failure to disconnect all power to the panel before working inside could result in serious injury or death.

De-energize main feed to the panel and follow appropriate Lockout/Tagout procedures as mandated by NFPA 70E. It is important to note that electrical equipment such as breaker panels can present an arc flash hazard if improperly serviced. This is due to the high amounts of short-circuit current available on the electrical supply to this equipment. Any work must comply with OSHA Safe Working Practices.

- 2: Remove the breaker(s) that reported the error.
- 3: Visually inspect the contacts on the bottom of the breaker and the mating contacts within the panel for damage. If you see any damage, contact ETC technical services for assistance
- 4: Re-seat the breaker, making sure it is firmly seated in place.
- 5: Replace the panel covers.
- 6: Re-energize the panel and check that the problem has been resolved.

Dim Overtemp

This error message only applies to ERP and EchoDIN panels fitted with dimmer modules and EchoDIN systems with a dimmer.

The dimmer overtemp message indicates that a dimmer or dimmers within the panel are running too hot.

To troubleshoot, check that the temperature of the room where the panel is installed is within the recommended temperature and humidity range, and that any ventilation or air conditioning systems are functioning appropriately.

Appendix D

Web UI

The Power Control Processor features a basic web UI that is accessible over the system network using any internet browser (such as Internet Explorer®, Firefox™, Safari®, or Chrome®). This allows you to view the system status, perform basic panel functions, update firmware, and upload or download the rack configuration.

To access your relay or breaker panel over the network:

- 1: Connect an internet browsing device (such as a computer) to the system network. You can connect using the network connector on the Ethernet Interface card.
- 2: Verify that the Power Control Processor web UI is enabled. Navigate to **[Arch Setup] > Network Settings** and set "Web Interface" to "On". See [Web Interface](#) on [page 26](#).
- 3: Set the connected device to the proper IP address range if using a system of fixed IP addresses. The default address will be set to 10.101.165.101. If your system uses dynamically assigned addresses (DHCP), your address will be assigned from the system server.
- 4: Open an internet browser on the connected device.
- 5: In the browser address bar, enter the IP address of the Echo Relay Panel you wish to view. The address can be found by navigating to **[Arch Setup] > Network Settings** and noting the digits in the "IP:" field. The "System" page will appear in the browser.

The home page menu provides access to the six available pages of the interface: [System](#), [Relays](#), [Set Levels](#), [Presets](#), [Sequences](#), and [Files](#).

System

This page displays the software and power information for the panel and all installed option cards, as well as any currently active error messages.

Rack-A210	Panel Controller
System	Rack Type: ERP
Relays	
Set Levels	Software Versions
Presets	Main Software Version 3.1.0
Sequences	Network Option Card Version 3.0.0
Files	Primary DALI/FLO version 1.0.1.9.0.22
	Secondary DALI/FLO version 0.0.0.0.0.0
	Contact In version 1.0.0.9.0.2
	Power Information
	Incoming Voltage 120V
	Errors
	Timed Event Hold

Relays

This page allows you to view the current status of all circuits in the panel, including:

- Relay output position
- Circuit number
- Breaker status
- Output level
- Load in watts
- Percentage of control level

You also have the option to turn circuits on and off from this screen.

Circuit	Breaker	Output	Load	Control
1	on	off	0.0A (0.0W)	-% (-)
2	on	on	0.2A (0.242W)	100% (Set)
3	on	off	0.0A (0.0W)	-% (-)
4	off	off	0.0A (0.0W)	-% (-)
5	on	off	0.0A (0.0W)	25% (sACN)
6	on	off	0.0A (0.0W)	25% (sACN)
7	on	off	0.0A (0.0W)	-% (-)
8	on	off	0.0A (0.0W)	-% (-)
9	on	off	0.0A (0.0W)	-% (-)
10	on	off	0.0A (0.0W)	-% (-)
11	on	off	0.0A (0.0W)	-% (-)
12	on	off	0.0A (0.0W)	-% (-)
13	No Relay			
14	No Relay			

Set Levels

This page allows you to set and release levels for any circuit or range of circuits in the panel.

You can use the displayed keypad or a connected keyboard to input commands into the green command window.

Once the command line reaches complete syntax it will be automatically entered as signified by a "*" at the end of the command line.

- If your system is divided into more than one space, you will first need to select the desired space using the "Select Space" field at top of the screen. See [Spaces](#) on [page 10](#).
- Use "and" and "thru" to select multiple circuits or ranges of circuits.
- Use "rel" to release channels.
- Use "Release All" to release all current levels.
- Use "Previous" and "Next" to cycle through successive channels.
- "Clear" clears the command window.

[Keyboard Shortcuts](#)

Presets

The Presets page allows you to record, activate, and deactivate presets for individual circuits. Presets are directly tied to the Spaces that have been pre-configured into the panel. For more information on Spaces, see [Spaces](#) on [page 10](#).

When you click on “Record” the current relay parameters will be recorded into the preset.

Rack-A210

Presets

System	Select Space :	Space 1 (1) ▾			
Relays	Preset 1	Activated	Activate	Deactivate	Record
Set Levels	Preset 2	Deactivated	Activate	Deactivate	Record
Presets	Preset 3	Deactivated	Activate	Deactivate	Record
Sequences	Preset 4	Deactivated	Activate	Deactivate	Record
Files	Preset 5	Deactivated	Activate	Deactivate	Record
	Preset 6	Deactivated	Activate	Deactivate	Record
	Preset 7	Deactivated	Activate	Deactivate	Record
	Preset 8	Deactivated	Activate	Deactivate	Record
	Preset 9	Deactivated	Activate	Deactivate	Record
	Preset 10	Deactivated	Activate	Deactivate	Record
	Preset 11	Deactivated	Activate	Deactivate	Record
	Preset 12	Deactivated	Activate	Deactivate	Record
	Preset 13	Deactivated	Activate	Deactivate	Record
	Preset 14	Deactivated	Activate	Deactivate	Record
	Preset 15	Deactivated	Activate	Deactivate	Record
	Preset 16	Deactivated	Activate	Deactivate	Record

Sequences

The Sequences page allows you to play back sequences that have been pre-programmed within the panel. For information on programming a Sequence, see [Sequences](#) on [page 32](#).

All Spaces that have been pre-programmed into the panel will be available from the menu near the top of the screen. The system defaults to Space 1 (1). For additional information on Spaces, see [Spaces](#) on [page 10](#).

Rack-A210

Sequences

System	Select Space :	Space 1 (1) ▾		
Relays	Sequence 1	Stopped	Start	Stop
Set Levels				
Presets				
Sequences				
Files				

Files

The Files page allows you to upgrade new versions of firmware, and download or upload a rack configuration.

To upload a file:

- 1: Select the file type (Configuration or Firmware) by clicking the appropriate option.
- 2: Use the "Browse" button to navigate to the desired file on your connected device.
- 3: When the file name appears in the field, click "Begin Upload".

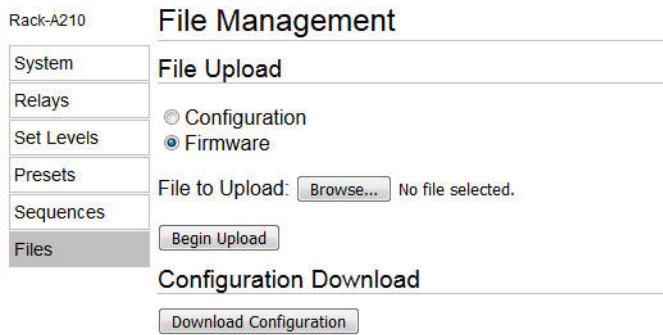

To download a configuration:

- 1: Click "Download Configuration". The system will compile the panel's configuration and a dialog box will open asking if you'd like to save or open the file.
- 2: Save the .cfg file to the desired location.



Corporate Headquarters Middleton, WI, USA +1 608 831 4116 **London, UK** +44 (0)20 8896 1000
Holzkirchen, DE +49 (80 24) 47 00-0 **Rome, IT** +39 (06) 32 111 683 **Hong Kong** +852 2799 1220 **Paris, FR** +33 1 4243 3535
Web etconnect.com **Support** etconnect.com/contactETC
© 2019 Electronic Theatre Controls, Inc. Trademark and patent info: etconnect.com/ip
Product information and specifications subject to change. ETC intends this document to be provided in its entirety.
7123M2400-3.1.0 Rev A Released 2019-01