



ArcSystem Pro D4 Series Drivers Installation Guide

Part Number: 7490M2170 Rev: F

Released: 2023-02

To view a list of ETC trademarks and patents, go to etcconnect.com/ip. All other trademarks, both marked and not marked, are the property of their respective owners.

ETC intends this document, whether printed or electronic, to be provided in its entirety.

Table of Contents

Introduction	1
Document Conventions	1
Help from ETC Technical Services	2
Safety	3
Label Symbols	3
Chapter 1 System Overview	4
ArcSystem Pro One-Cell and Pro One-Cell Small Luminaires	4
Third-Party Fixtures	4
D1 Series, D2 Series, and D4 Series Drivers	5
TX1 Transmitter	6
ArcMesh	6
ArcMesh Specifications	7
Emergency System Overview	7
Before You Begin Installation	9
Power Disconnect Device	9
Site Survey for Wireless Installations	9
Installation Requirements	9
Chapter 2 Preparing the Ceiling for Recessed Luminaires	11
Extension Cables	12
Chapter 3 D4 Series Wall-Mount Driver Installation	13
Electrical and Wiring Specification	13
Wire and Terminal Specifications	14
Prepare for Wall-Mount Installation	15
Wall-Mounting Supplies	15
Wall-Mount the Driver	15
Terminate Wiring	16
Wall-Mount Driver Wiring Overview	16
Power Input Wiring	18
Output Wiring	20

	DMX In and DMX Thru	21
	D4 Driver 150 Current Configuration	22
Chapter 4	D4 Series Rack-Mount Driver Installation	23
	Electrical and Wiring Specification	23
	Prepare for Rack-Mount Installation	23
	Rack-Mounting Safety	24
	Terminate Wiring	24
	Power Input Wiring	25
	Output Wiring to Fixture	25
	Bridging Output Channels	25
	DMX In and DMX Thru	26
Chapter 5	One-Cell Luminaire Installation	27
	Installing One-Cell Recessed Luminaires	27
	Installing One-Cell Yoke-Mounted Luminaires	28
Chapter 6	Emergency System One-Cell Installation	29
	Emergency Driver Power Input Wiring	29
	Wall-Mount Emergency Drivers	30
	Wall-Mount Emergency Driver Installation	32
	Rack-Mount Emergency Drivers	36
Chapter 7	Final Installation and Operation	38
	Power Up Procedure	38
	Updating the Luminaire Firmware	38
	Wireless ArcMesh Luminaires	38
	RDM Luminaires	38
	Commissioning a Wireless ArcSystem	39
	DMX System Control	39
	RDM Values	40
	Maintenance	42
	Emergency Operation and Test	43
	Troubleshooting	44
	LED Indicators	44
	Overload Protection	45
Appendix A	Bridge D4 Series Constant Voltage Driver	46

Output Channels	
Voltage Drop	48
Wall-Mount Bridging Kits	48
Rack-Mount Bridging Kits	48
Output Channel Control Switches	49
Example Bridge Configurations	52
Bridging Procedure	55
 Appendix B Compliance	 56

Introduction

Congratulations on your purchase of ArcSystem products. ArcSystem is a family of overhead LED products designed for installations where dimming, light quality, and ease of installation are absolutely essential. With ArcSystem, you will experience perfectly smooth dimming from 100% down to absolute zero. ArcSystem luminaires come in a variety of form factors, beam angles, and color-temperature options, all with high-efficiency optics and an outstanding quality of light ideal for any application.

ArcSystem products with ArcMesh can be controlled using wired DMX or the wireless ArcMesh protocol. ArcSystem products without ArcMesh can be configured for RDM control. This manual provides step by step instruction on the installation of ArcSystem Pro One-Cell luminaires, D4 Series Drivers, and full system integration. For more information on ArcMesh or other ArcSystem Pro drivers and luminaires, see the manuals listed below. All ETC manuals are available for download free of charge at etconnect.com.

- *ArcSystem Pro Installation Manual* for information on ArcSystem Pro One-Cell and Multi-Cell luminaires with wireless ArcMesh control using the ArcSystem Pro TX1 Transmitter
- *ArcSystem Pro D1 and D2 Series Drivers Installation Guide* for information on installing D1, D1 HO, and D2 Series drivers and one-cell luminaires
- *ArcSystem Pro Multi-Cell RDM Installation Guide* for information on installing RDM multi-cell luminaires

Document Conventions

This document uses the following conventions to draw your attention to important information.



Note: *Notes are helpful hints and information that is supplemental to the main text.*



CAUTION: *A Caution statement indicates situations where there may be undefined or unwanted consequences of an action, potential for data loss or an equipment problem.*



WARNING: *A Warning statement indicates situations where damage may occur, people may be harmed, or there are serious or dangerous consequences of an action.*



WARNING: RISK OF ELECTRIC SHOCK! *This warning statement indicates situations where there is a risk of electric shock.*

All ETC documents are available for free download from our website: etconnect.com.

Please email comments about this manual to: TechComm@etconnect.com.

Help from ETC Technical Services

If you have questions that are not answered by this document, try the ETC support website at support.etconnect.com or the main ETC website at etconnect.com. If none of these resources are sufficient, contact ETC Technical Services directly at one of the offices identified below. Emergency service is available from all ETC offices outside of normal business hours.

When calling for help, take these steps first:

- Prepare a detailed description of the problem
- Go near the equipment for troubleshooting
- Find your notification number if you have called in previously

ETC, Inc. *Americas*

Technical Services Department
3031 Pleasant View Road
Middleton, WI 53562
800-775-4382 (USA, toll-free)
+1-608 831-4116
service@etconnect.com

ETC Austin *High End Systems Products*

Technical Services Department
2105 Gracy Farms Lane
Austin, TX 78758 USA
800-890-8989 (USA, toll-free)
+1-512 836-2242
hesservice@etconnect.com

ETC Ltd *Europe, Middle East, and Africa*

Technical Services Department
26-28 Victoria Industrial Estate
Victoria Road,
London W3 6UU England
+44 (0)20 8896 1000
techservltd@etconnect.com

ETC GmbH *Germany, Austria, Switzerland, Eastern Europe, and Russia*

Technical Services Department
Ohmstrasse 3
83607 Holzkirchen, Germany
+49 (80 24) 47 00-0
techserv-germany@etconnect.com

ETC France *France*

Zone Urbaparc -
Bâtiment E
6 Boulevard de la Libération
Saint-Denis, 93200
+33 1 4243 3535
techservfrance@etconnect.com

ETC Asia *Asia*

Technical Services Department
Room 1801, 18/F
Tower 1, Phase 1 Enterprise Square
9 Sheung Yuet Road
Kowloon Bay, Kowloon, Hong Kong
+852 2799 1220
techserv-asia@etconnect.com

Safety

ArcSystem products are intended for professional use only. **Read the entire manual before using this equipment.**

IMPORTANT SAFEGUARDS

When using electrical equipment, basic safety precautions should always be followed including the following:







READ AND FOLLOW ALL SAFETY INSTRUCTIONS

- Do not use outdoors.
- Do not let power supply cords touch hot surfaces.
- Do not mount near gas or electric heaters.
- Equipment should be mounted in locations and at heights where it will not readily be subjected to tampering by unauthorized personnel.
- The use of accessory equipment not recommended by the manufacturer may cause an unsafe condition.
- Do not use this equipment for other than intended use.

SAVE THESE INSTRUCTIONS

Label Symbols

ArcSystem luminaires and drivers are conveniently labeled with relevant symbols for your safety. Refer to the product label to see which symbols apply to your product.

	General warning	Avertissement général
	This product should not be discarded as unsorted waste but must be sent to separate collection facilities for recovery and recycling.	Ce produit ne doit pas être jeté avec les déchets ménagers mais doit être déposé dans une collecte de déchets électroniques ou dans un point de collecte.
	The product input or output is suitable for direct current only.	L'entrée et la sortie de ce produit convient uniquement au courant continu.
	The product input or output is suitable for alternating current only.	L'entrée et la sortie de ce produit convient uniquement au courant alternatif.
	Safety extra low voltage device	Dispositif de sécurité à très basse tension
	Independent lighting control gear	Appareil de contrôle d'éclairage indépendant.
t_c	Rated maximum case temperature	Température maximale recommandée pour le boîtier

Chapter 1

System Overview

ArcSystem Pro D4 Drivers support ArcSystem Pro One-Cell and Pro One-Cell Small luminaires or a variety of third-party loads. For complete specifications, view the product datasheets at etcconnect.com/ArcSystem.

ArcSystem Pro One-Cell and Pro One-Cell Small Luminaires

Luminaire Mounting Options	Driver	Power Input Options
<ul style="list-style-type: none"> fixed version: recessed/flush mount (standard luminaire only) adjustable version: recessed/flush mount with two-axis tip and tilt yoke-mount version with single axis tilt (small luminaire only) 	D1 Series driver	<ul style="list-style-type: none"> 100–277 VAC, 50/60Hz hard-wired (non-emergency models) Normal: 100–277 VAC, 50/60Hz, Maintained: 100–277 VAC, 50/60Hz, hard-wired (emergency models for all regions)
	D4 150 CC driver	<ul style="list-style-type: none"> 100–240 VAC, 50/60Hz hard-wired (non-emergency models) 277 VAC, 50/60 Hz hard-wired (non-emergency models, model ends in "-277") Normal: 100–240 VAC, 50/60Hz, Maintained: 100–240 VAC, 50/60Hz, hard-wired (emergency models) Normal: 277 VAC, 50/60Hz, Maintained: 277 VAC, 50/60Hz, hard-wired (emergency models, model ends in "-277")

Third-Party Fixtures

D4 Drivers support a wide variety of third-party loads. Determining compatibility between these loads and the driver is an important step toward ensuring the success of a project. Search the [LED Dimming Compatibility Database](http://etcconnect.com/compatibility) at etcconnect.com/compatibility to see if your load is compatible. If your load is not in the compatibility database, follow the instructions at the link above to contact the ETC Applications Engineering department to arrange for compatibility testing.

Third-party constant current fixtures or constant voltage fixtures can be connected directly to a D4 CC driver or D4 CV driver using the terminal outputs.

Driver	Output	Power Input Options
D4 150 CC Wall-Mount	48 VDC, 400 mA or 600 mA per output channel, with a maximum total output of 2.4 A or 100 W	<ul style="list-style-type: none"> 100–240 VAC, 50/60Hz hard-wired (non-emergency models) 277 VAC, 50/60 Hz hard-wired (non-emergency models, model ends in "-277") Normal: 100–240 VAC, 50/60Hz, Maintained: 100–240 VAC, 50/60Hz, hard-wired (emergency models) Normal: 277 VAC, 50/60Hz, Maintained: 277 VAC, 50/60Hz, hard-wired (emergency models, model ends in "-277")
D4 150 CV Wall-Mount	24 VDC and up to 50 W per output channel, with a maximum total output of 6.25 A or 150 W	Normal: 100-277 VAC, 50/60 Hz, Maintained (emergency): 100–277 VAC, 50/60 Hz (emergency drivers only)
D4 350 CC or D4 700 CC driver	48 VDC, 400 mA or 600 mA per output channel, with a maximum total output of 2.4 A or 100 W	100–240 VAC, 50/60 Hz with IEC connector (non-emergency models) or hard-wired (emergency models)
D4 350 CV Wall-Mount or Rack-Mount	24 VDC and up to 72 W per output channel, with a maximum total output of 11 A or 264 W	Normal: 100-240 VAC, 50/60 Hz, Maintained (emergency): 100–240 VAC, 50/60 Hz (emergency drivers only)
D4 700 CV Wall-Mount or Rack-Mount	24 VDC and up to 146 W per output channel, with a maximum total output of 22 A or 528 W	

D1 Series, D2 Series, and D4 Series Drivers

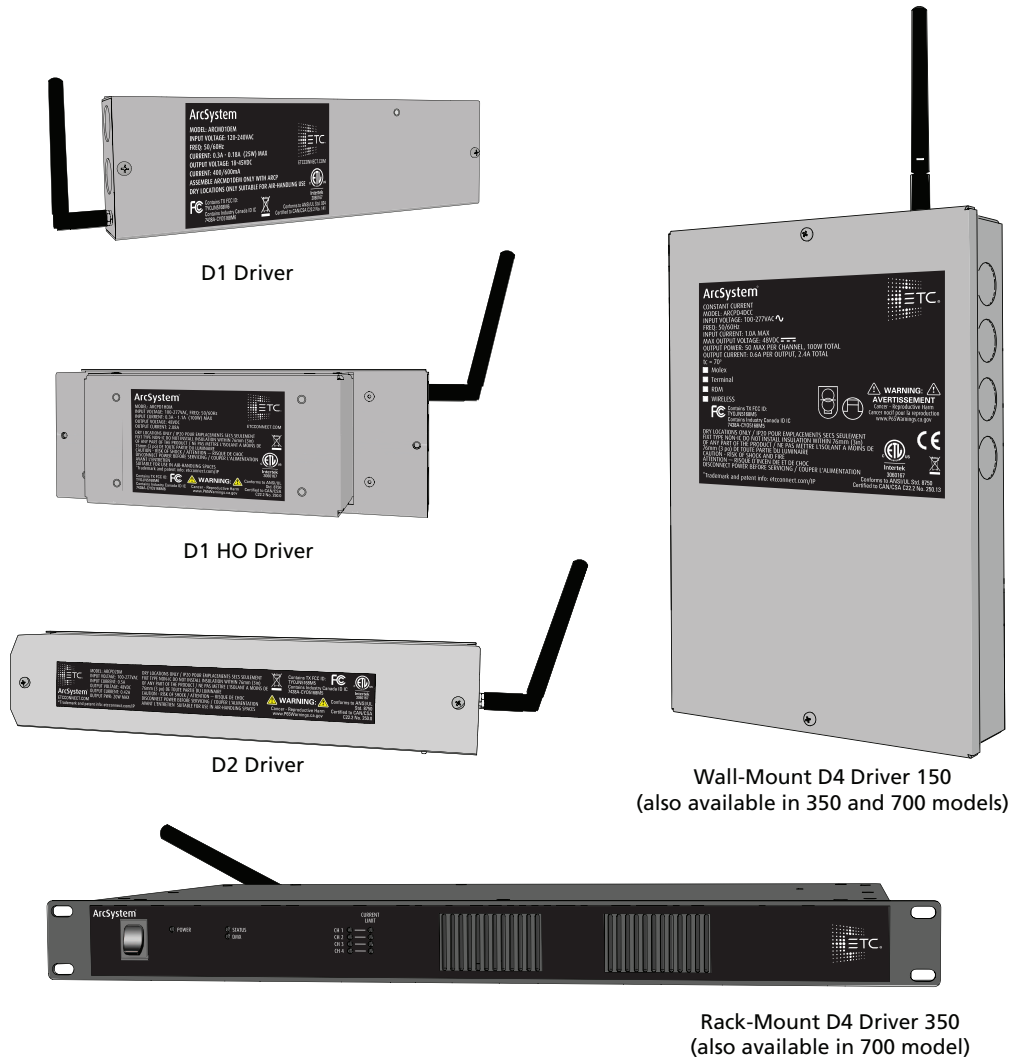

Note: Antenna is not present on RDM models.

ArcSystem Pro One-Cell luminaires require an external driver. ArcSystem D1, D2, and D4 Series drivers use standard RJ45 connectors for DMX control.

- The D4 150 Constant Current (CC) Driver with Molex connectors supports four One-Cell or One-Cell Small luminaires.
- D4 Drivers with terminals support third-party loads. See [Third-Party Fixtures on the previous page](#).

For more information on installation of standard or emergency D1 or D2 series drivers, see the [ArcSystem Pro D1 and D2 Series Installation Guide](#) at etconnect.com/ArcSystem.

TX1 Transmitter

The TX1 Transmitter is the DMX wireless gateway for the ArcMesh protocol, featuring:

- Control of up to 100 devices across 64 DMX addresses
- 24 preset scene memory
- DMX wired output for control of third party equipment within scene store
- Two auxiliary inputs for closed contact connection to trigger a stored scene

Each transmitter can be set to one of 16 available network IDs allowing multiple transmitters to be used concurrently without “cross-talk.” When two or more transmitters are set to the same network ID and radio channel, the transmitter with the highest MAC address acts as a master with the others assuming the role of backup.

For information on installing the ArcSystem TX1 Transmitter for use with ArcMesh installations, see the *ArcSystem Installation Manual* at etconnect.com/ArcSystem.

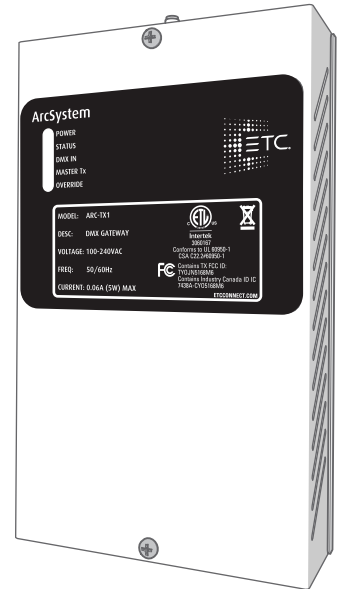

Note: All ArcSystem wireless luminaires require a TX1 Transmitter and commissioning tool to set DMX addresses for both wired DMX and wireless installations. Contact your ETC Service Technician for more information.



Note: By default the TX1 DMX output is disabled. If you require DMX output from the TX1, you must use the ArcSystem commissioning tool software to add DMX fixtures.

ArcMesh

ArcSystem products can be controlled using wired DMX through RJ45 connections, or the wireless ArcMesh protocol. A wireless installation is an ideal solution for retrofit situations where installing additional cable is not practical.

Each system requires a minimum of one TX1 Transmitter. The TX1 is used as a transmitter of wireless data to luminaires or other devices within a system. The following diagram illustrates a basic hybrid ArcSystem installation with a wireless luminaire, TX1 Transmitter, and a wired DMX console for the main control source.

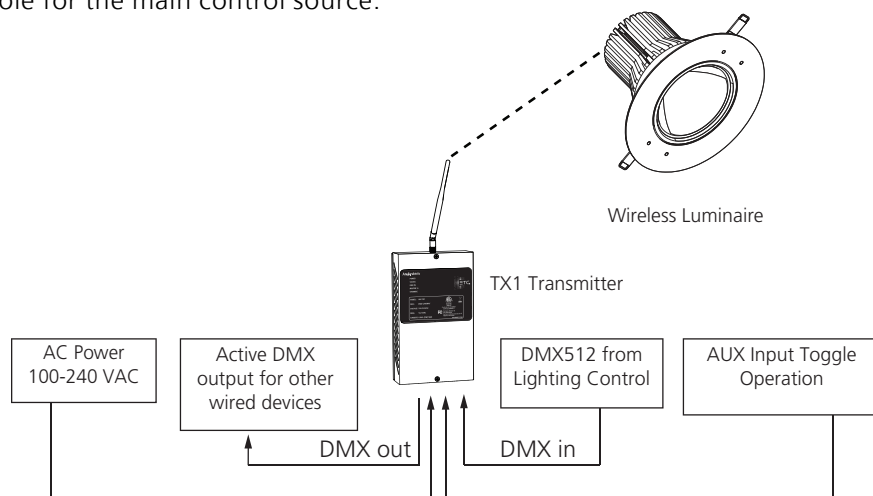

ArcMesh Specifications

- Use up to 100 devices per TX1 transmitter.
- Patch up to 64 ArcMesh channels to 512 DMX channels.
- Use up to 16 TX1 transmitters per system.

There are no system range limitations for transmitting data between luminaires because each luminaire has the ability to act as a repeater (see Re-Broadcast Mode below). ArcSystem is self-regulating and continues to reconfigure the communication “mesh” to establish the most successful path of communication transmission.

Re-Broadcast Mode

By default all ArcSystem luminaires are shipped with re-broadcast mode turned off to reduce the amount of wireless activity. In areas of poor wireless reception, re-broadcast mode may be enabled on a luminaire-by-luminaire basis to improve the overall signal level of the system.

For more information about ArcMesh and re-broadcast mode, download the *ArcSystem Wireless Information Guide* from etconnect.com.

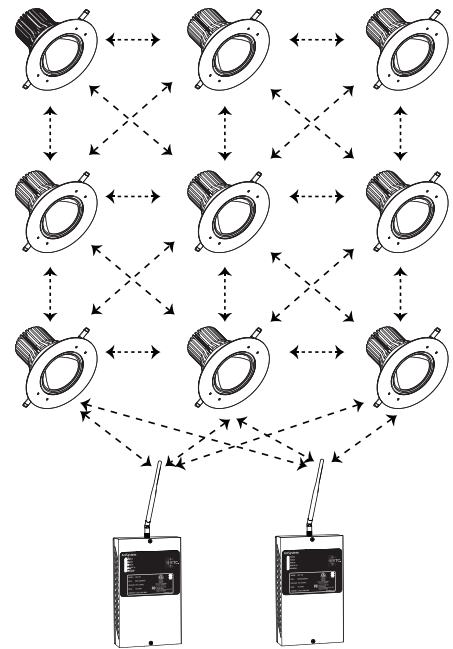

Emergency System Overview

ArcSystem drivers and luminaires can be purchased in UL924 listed variants. Each of the luminaires can be configured to be UL924 listed when wired into an existing emergency response system. See [Emergency System One-Cell Installation on page 29](#).

Install the luminaire and ArcSystem D1, D2, or D4 Series driver in a location that is accessible by qualified personnel for testing of the emergency operation.



Note:

- Luminaires must be hard-wired to emergency certified drivers to be considered for UL924 certification.
- The number of designated emergency lamps and their height is the responsibility of the specifier and installer in order to achieve the minimum FC levels of NFPA 101. Installation scenarios should be evaluated by the AHJ to confirm illuminance and performance requirements of ANSI/NFPA 101 and the IBC.
- Installation must follow all national and local codes for electrical equipment.
- Normal and emergency wiring cannot be contained in the same conduit according to NEC 700.10(B).

Emergency drivers and luminaires require two branch circuit connections. These inputs have the following functions:

1. Normal branch circuit to sense failure of the normal supply. Connect to Sense Input connector.
2. Normal/Emergency branch circuit providing power to the luminaire in both conditions. Connect to Maintained Input connector.

Sense detects when power is lost and forces the luminaire to a full-on state, powered by the emergency supply through the Constant Power input. Control of the luminaire will not be available until the sense input has been restored.



WARNING: Do not mix 120 V and 277 V between the sense and emergency feeds.

AVERTISSEMENT : Ne pas inverser les alimentations à 120 V et 277 V entre les alimentations de détection et de secours.



WARNING: Sense (normal) and Maintained (normal/emergency) feeds must have the same phase. The diagram below shows the recommended installation.

AVERTISSEMENT : Les alimentations de détection (normale) et d'entretien (normal/secours) doivent être sur la même phase. Le schéma ci-dessous présente l'installation recommandée.

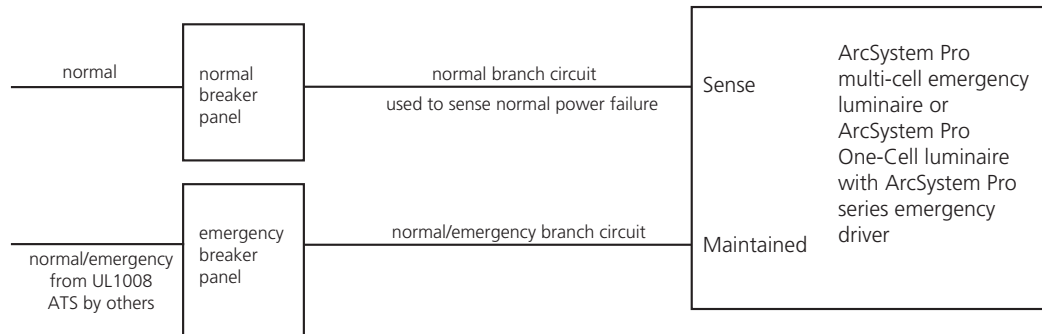

Before You Begin Installation

Review the following sections before beginning your ArcSystem installation. ArcSystem products should only be installed by a qualified installer or electrician.

Power Disconnect Device

Before installation, make sure you have a readily accessible input power disconnect device installed ahead of your ArcSystem products.



WARNING: RISK OF DEATH BY ELECTRIC SHOCK! Failure to disconnect all power to the system before installation, maintenance, cleaning, or any other system modification could result in serious injury or death.

AVERTISSEMENT : RISQUE DE MORT PAR DÉCHARGE ÉLECTRIQUE! Négliger de débrancher toutes les sources d'alimentation du système avant l'installation, l'entretien, le nettoyage ou toute autre modification du système peut causer des blessures graves ou la mort.

De-energize main feed to ArcSystem and follow appropriate Lockout/Tagout procedures as mandated by NFPA 70E. It is important to note that electrical equipment such as breaker panels can present an arc flash hazard if improperly serviced. This is due to the high amounts of short-circuit current available on the electrical supply to this equipment. Any work must comply with OSHA Safe Working Practices.



WARNING: RISK OF ELECTRIC SHOCK! Circuits that are installed without an accessible power disconnect device cannot be serviced or operated safely.

AVERTISSEMENT : RISQUE DE DÉCHARGE ÉLECTRIQUE! Il est imprudent d'utiliser ou de réparer les circuits installés sans qu'un dispositif de déconnexion de l'alimentation ne soit accessible.

Site Survey for Wireless Installations

ArcSystem transmitters and luminaires operate in the unlicensed 2.4 GHz band using the IEEE 802.15.4 standard. This band is shared with other technologies such as Wi-Fi, Bluetooth, low power sensor networks, wireless AV transmitters and some radio microphones.

Before commissioning a system, a wireless site survey is essential.

Gathering information on how your wireless lighting system will overlap with all other Wi-Fi traffic in the area will help determine setup of transmitters and which luminaires should be re-broadcasting, not just receiving wireless data.

Installation Requirements

- Indoor installation only: 0–40°C (32–104°F), 5–95% non-condensing humidity.
- Dry locations only.
- Installation location must support the weight of the luminaire, driver, and applicable mounting hardware.



CAUTION: *ArcSystem luminaires and drivers are not suitable for use in spaces with restricted air flow. Enclosing the luminaires or drivers temporarily or permanently may cause damage to the luminaires or drivers.*

D4 Rack-Mount Driver

Rack-mounted D4 drivers require a 19-inch equipment rack. Each D4 driver requires one unit (1U) of rack space.



Note: *Install this device in a location with restricted access where only qualified personnel and service persons can gain access with the use of a key. If this equipment is installed in a location without restricted access, the wiring area of the rack should only be accessible with the use of a tool.*

D4 Wall-Mount Driver

Wall-mounted D4 drivers require 7.6 cm (3 in) clearance around the side vents for proper ventilation.

D4 150 Constant Current Driver

See [D4 Driver 150 Current Configuration on page 22](#) for important details about configuring a D4 150 CC driver for third-party loads.

D4 Constant Voltage Drivers and Voltage Drop

Consult the manufacturer's documentation for your load to find the minimum voltage required for operation. Voltage drop calculations vary by project and are based on the type, length, and gauge of wire used between the D4 Driver and load. Contact a qualified electrician or ETC technical services for further information.

Chapter 2

Preparing the Ceiling for Recessed Luminaires

This section is specific to recessed (flush-mount) luminaires. For yoke-mounted luminaires, see [Installing One-Cell Yoke-Mounted Luminaires on page 28](#).

The luminaire retaining clips accommodate 3–24 mm (1/8–15/16 in) ceiling thickness. Cut a hole in the ceiling or ceiling tile to accommodate the luminaire’s retaining clip anchors. Cut the hole larger than the minimum hole diameter listed to the right and smaller than the luminaire’s outer bezel.

Luminaire	Minimum Hole Diameter
Pro One-Cell	16.5 cm (6-1/2 in)
Pro One-Cell Small	9.5 cm (3-3/4 in)



Note: Maximum ceiling thickness for safe use of the luminaire retaining clips is 24 mm (15/16 in).

The images below provide an example of the bezels on the Pro One-Cell luminaires.

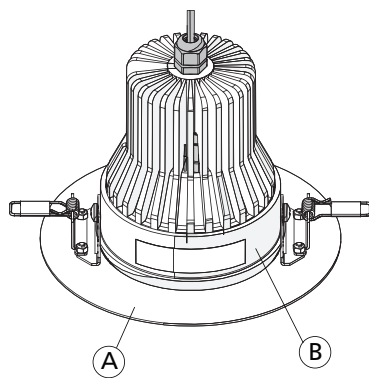

Pro One-Cell
fixed model

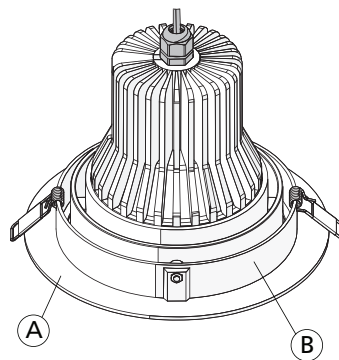

Pro One-Cell
adjustable model

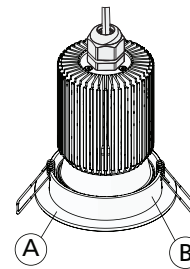

Pro One-Cell Small
adjustable model

A	Outer bezel
B	Inner bezel

Extension Cables

Extension cables can be used between an ArcSystem Pro D1 Series, D2 Series, or D4 CC driver and a compatible ArcSystem Pro One-Cell, One-Cell Small, or One-Cell Micro luminaire.

Part Number	Description
ARCDAHBC1	1 m (3 ft 3 in) extension cable
ARCDAHBC2	2 m (6 ft 7 in) extension cable
ARCDAHBC3	3 m (9 ft 10 in) extension cable
ARCDAHBC5	5 m (16 ft 5 in) extension cable
ARCDAHBC10	10 m (32 ft 10 in) extension cable



Note: *Maximum supported wire length between One-Cell luminaires and D1 Series, D2 Series, and D4 CC drivers is 15 m (49 ft, 3 in).*

Chapter 3

D4 Series Wall-Mount Driver Installation

This section provides information on how to install wall-mount D4 Series constant current (CC) and constant voltage (CV) drivers. The D4 Constant Current Driver can control up to four ArcSystem Pro One-Cell or Pro One-Cell Small luminaires. Up to 32 drivers can be installed on one hard-wired line of DMX.

Electrical and Wiring Specification



WARNING: RISK OF ELECTRIC SHOCK! Circuits that are installed without an accessible power disconnect device cannot be serviced or operated safely.

AVERTISSEMENT : RISQUE DE DÉCHARGE ÉLECTRIQUE! Il est imprudent d'utiliser ou de réparer les circuits installés sans qu'un dispositif de déconnexion de l'alimentation ne soit accessible.

Install the D4 Driver on a power distribution system with reliably identified earthed neutral and install a maximum appropriately-sized circuit breaker on the line conductor.

ETC recommends installing all wiring to and from wall-mount drivers in grounded metal conduit.

The wall-mount D4 150 CC driver accepts 100–240 VAC, 50/60 Hz or 277 VAC, 50/60 Hz (models ending in "-277"). D4 CV drivers (150, 350, and 700 models) accept 100–240 VAC, 50/60 Hz. Emergency models only: requires normal sense and maintained (emergency) input power.



Note: *Minimum 2.5 mm² (14 AWG) output wire size is recommended with D4 CV drivers. See etconnect.com/compatibility and contact Systems for assistance with voltage drop calculations based on power required and run length.*

Wire and Terminal Specifications

Terminal / Connector	Wire Range / Specification	Strip Length	Torque Rating
D4 150 CV standard and emergency driver Power Input D4 150 CC standard and emergency driver Power Input	Standard and emergency models maintained input (line/neutral): 0.5–10 mm ² (22–6 AWG)	7 mm (1/4 in)	0.5 Nm (4 in-lb)
	Standard and emergency models maintained input (ground): 2.5–10 mm ² (14–6 AWG)	10 mm (3/8 in)	4.0 Nm (35 in-lb)
	Emergency models sense input (line/neutral/ground): 0.2–2.5 mm ² (24–14 AWG)	6.5 mm (1/4 in)	0.5–0.6 Nm (4.4–5.3 in-lb)
D4 Driver 350 and 700 standard and emergency Power Input	line/neutral/ground: 0.5–1.5 mm ² (22–16 AWG)	10 mm (3/8 in)	none
24 VDC Power Output	D4 150 CV standard and emergency models with terminals: 1.5 mm ² (14 AWG) using the provided two-terminal connectors. Follow Class 1 wiring methods.	6 mm (1/4 in)	0.4–0.5 Nm (3.5–4.4 in-lb)
	D4 350 and 700 standard and emergency drivers: 2.5 mm ² (14–12 AWG, solid or stranded). Follow Class 1 wiring methods.	10–12 mm (3/8–1/2 in)	none
48 VDC Output	D4 150 CC standard and emergency drivers with terminals: 0.2–1.5 mm ² (26–14 AWG)	6 mm (1/4 in)	0.4–0.5 Nm (3.5–4.4 in-lb)
	D4 150 CC standard and emergency drivers with Molex connectors: use the cable attached to the ArcSystem Pro One-Cell luminaire. Follow class 2 wiring methods.		
DMX In/Thru RJ45 Connectors	Cat5e (or equivalent) 0.2 mm ² (24 AWG) or larger conductors terminated to T568B standard. You must terminate the last driver in line with a DMX terminator plug in the RJ45 Thru receptacle. See RJ45 DMX Termination on page 21		
DMX In/Thru Eight-pin Connector	D4 350 and 700 standard and emergency drivers: Belden 9729 (or equivalent). A 120Ω resistor (not provided) is required to terminate the last DMX device in a control run. See DMX Cable Preparation and Termination on page 1.		



Note: All output channels have onboard electronic overload protection. See [Overload Protection on page 45](#).

Prepare for Wall-Mount Installation



Note: *Mounting hardware and installation location must support the weight of the driver, conduit hardware, and all cable required for installation.*

Wall-Mounting Supplies

The following supplies are required, but not provided, for D4 Driver installation:

- flexible conduit and conduit fittings
- appropriate strain relief connectors for the installation type, as needed
- Phillips screwdriver
- four each mounting bolts or screws and wall anchors, as needed

Wall-Mount the Driver

1. Using a Phillips screwdriver, remove the two screws securing the cover to the D4 Driver enclosure. Set screws aside for later re-installation. The cover is grounded by a tether to the enclosure.
 - D4 Driver 350 and 700 wall-mount drivers have two hooks inside the cover and slots on the bottom side of the enclosure so that you can hang the cover during installation.
 2. Align the D4 Driver in its desired installation location and mark, then pre-drill the four mounting holes.
-



Note: *Vents on back of driver must **not** make contact with the wall for proper airflow.*

3. Install wall anchors as needed.
 4. Align the driver to the mounting location and install the mounting hardware. Secure the hardware.
 5. Install conduit hardware as required for your installation wire plan.
 - **D4 Driver 150 wall-mount drivers:** Remove the knockouts required based on your installation wire plan and install conduit hardware accordingly.
 - **D4 Driver 350 and 700 wall-mount drivers:**
 - a. Using a Phillips screwdriver, remove the five screws securing the removable panel on the left side of the enclosure.
 - b. Punch holes as needed for conduit for power connection and data connection.
 - c. Reinstall the removable panel to the backbox.
-



Note: *Make sure that the flexible electrical supply can extend through the ceiling opening so that the driver and luminaire can be inspected and serviced when needed.*



Note: *Use suitable conduit where required by national and local codes.*



Note: *Drivers may require additional means of securement. Installation must follow all national and local codes for electrical equipment.*

Terminate Wiring

Wiring of the driver consists of wiring power and data (DMX) to the driver for your luminaire and then running power out to the luminaire from the driver. If you are installing emergency system drivers, [Emergency System One-Cell Installation on page 29](#).

Wall-Mount Driver Wiring Overview

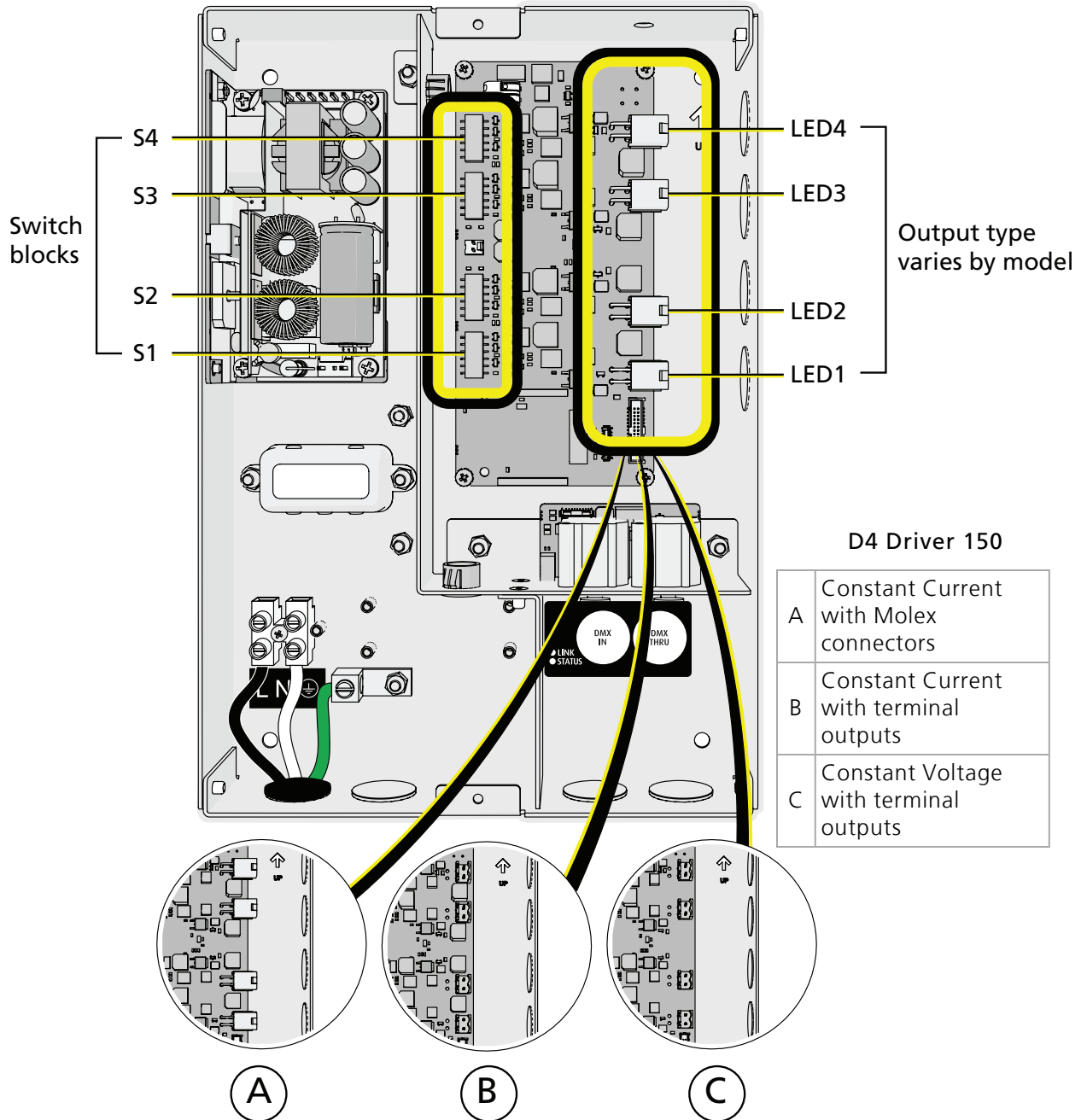

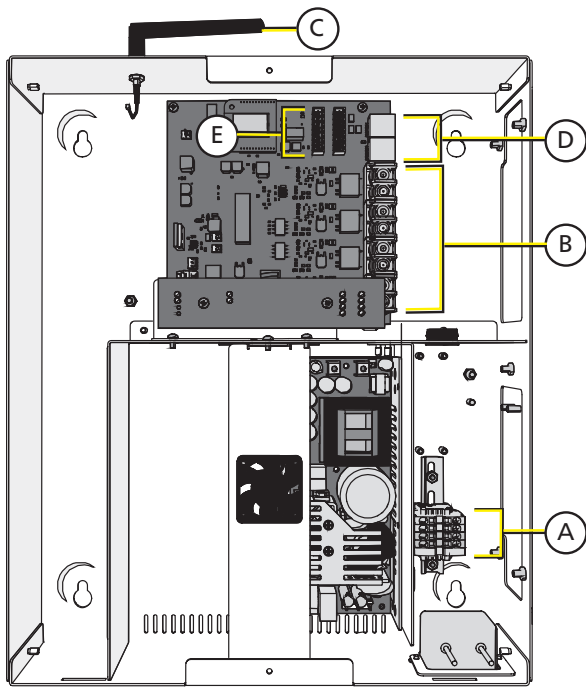

D4 Driver 350

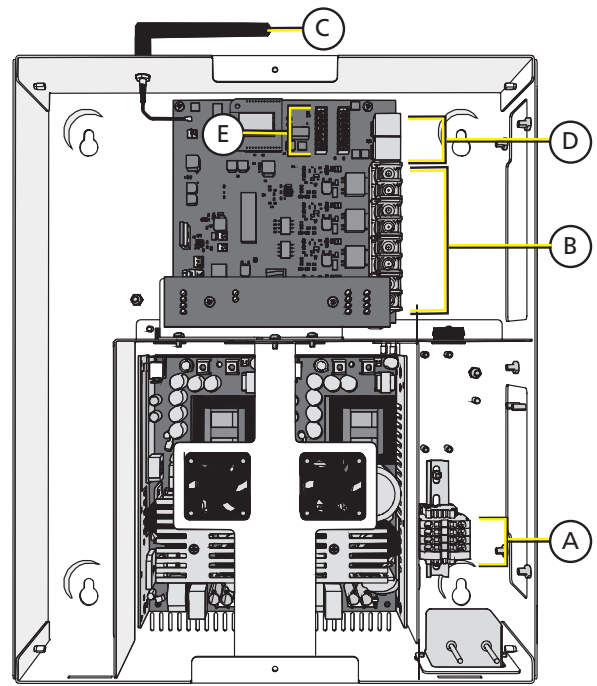

D4 Driver 700

A	Power input
B	Output channels
C	Antenna*
D	DMX input and thru (RJ45)
E	DMX input and thru (eight-pin terminal blocks)†

*The antenna is not present on RDM models.

†Eight-pin terminal blocks are not present on D4 Driver 150.

Power Input Wiring

This section provides power input wiring termination for standard wall-mount D4 Driver models. See [Emergency System One-Cell Installation on page 29](#).

D4 Driver 150

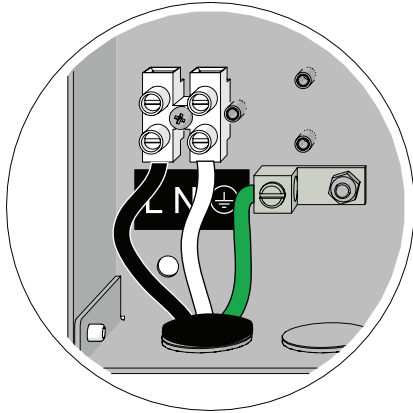

D4 Driver 150
Power Input Detail

Factory Wire Colors

Model	Color	Type
North America and Europe	green/yellow	ground/earth
North America	black	line/hot
North America	white	neutral
Europe	brown	live
Europe	blue	neutral



Note: Power wiring should only be installed and terminated by a qualified electrician and should follow standard wiring installation practices.

1. Make sure power is off at the main circuit breaker.
2. See [Wire and Terminal Specifications on page 14](#) for specification of wire, strip length, and terminal torque ratings. Prepare the wires accordingly.
3. Loosen the three screw terminals for NEUTRAL (N), GROUND (⊕), and LINE (L) connections.
4. Insert the ground wire (typically green) into the GROUND (⊕) terminal and tighten the screw.
5. Insert the neutral wire (typically white) into the NEUTRAL (N) terminal and tighten the screw.
6. Connect the hot wire (typically black) into the HOT (L) terminal and tighten the screw.
7. Tug gently on the wires to ensure they are secure.

Wall-Mount D4 Driver 350 and 700

Push-In Terminal Blocks

D4 Driver 350 and 700 wall-mount drivers have push-in terminal blocks. No tools are required to insert wires into the terminal block.

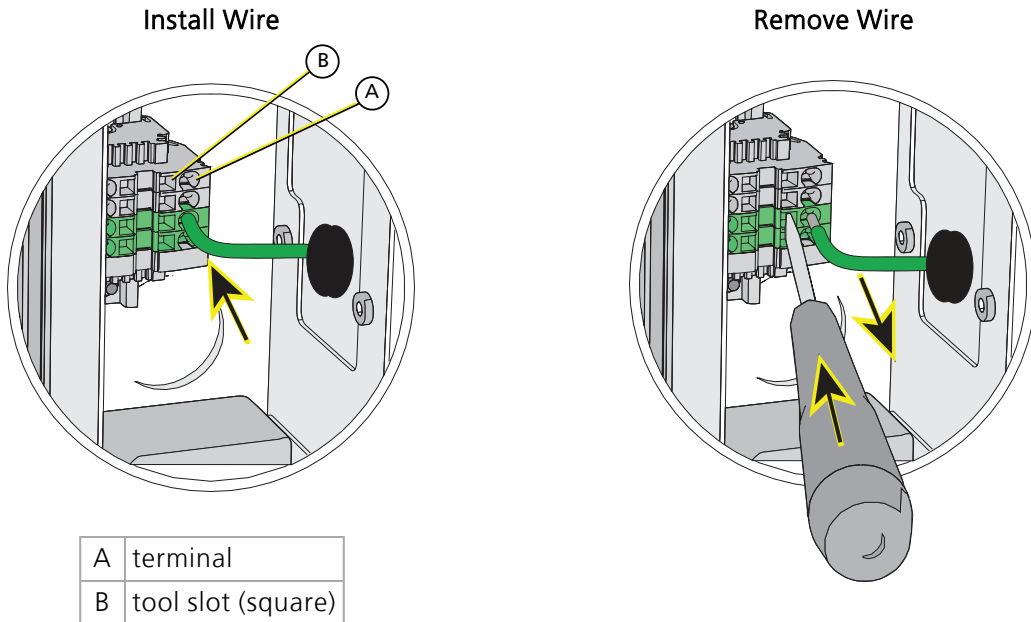

- To install wire, insert the wire into the terminal.
- To remove wire, insert a 3.5 mm flatblade screwdriver into the tool slot next to the wire terminal to release the wire, then pull the wire out of the terminal.

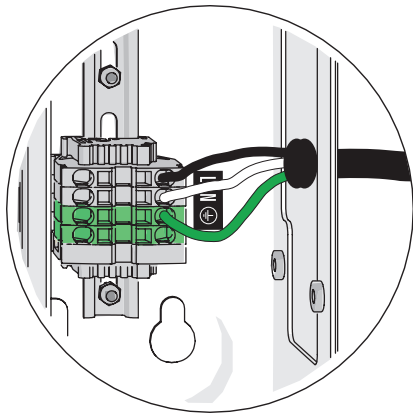

Wall-Mount D4 Driver 350 and 700
Power Input Detail

Factory Wire Colors

Model	Color	Type
North America and Europe	green/yellow	ground/earth
North America	black	line/hot
North America	white	neutral
Europe	brown	live
Europe	blue	neutral

Connect the Input Power

1. Make sure power is off at the main circuit breaker.
2. See [Wire and Terminal Specifications on page 14](#) for specification of wire size and strip length. Prepare the wires accordingly.
3. See [Push-In Terminal Blocks on the previous page](#) for general instructions on using the push-in terminal blocks.
4. Insert the ground wire (typically green) into the terminal marked "⊕".
5. Insert the neutral wire (typically white) into the terminal marked "N."
6. Terminate the line (hot) wire (typically black) into the terminal marked "L."
7. Tug gently on the wires to ensure they are secure.

Output Wiring

ArcSystem Pro One-Cell luminaires connect to a driver using Molex receptacles labeled "LED" followed by output channel number for D4 Series drivers. Some models of D4 Series drivers have Molex receptacles for ArcSystem Pro One-Cell luminaire connections. Other D4 Series drivers have two-pin terminal outputs that can be used to provide power and data to other constant-voltage loads.



Note: Maximum supported wire length between an ArcSystem Pro One-Cell or Pro One-Cell Small and a D4 150 CC driver is 15 m (49 ft, 3 in).



Note: Power wiring should only be installed and terminated by a qualified electrician and should follow standard wiring installation practices.

1. Install the ceiling with the prepared mounting hole for the luminaire.
2. Run the luminaire cable through the previously installed screw-clamp conduit connector at one of the driver knockouts.
3. Connect the luminaire cable to the driver output.

- **D4 Series Drivers with Molex receptacles:** connect the four-pin luminaire cables to the Molex receptacles inside the driver. Support the luminaires. Do not let luminaires hang by their cables.
- **D4 Drivers with terminal outputs:** wire constant-voltage loads to a provided two-pin connector and insert the connector into a two-pin terminal inside the driver. See the illustration at right.

4. Constant Current (CC) drivers: verify that each output channel's current output is configured correctly. See [D4 Driver 150 Current Configuration on page 22](#).

Two-Pin Output Terminals

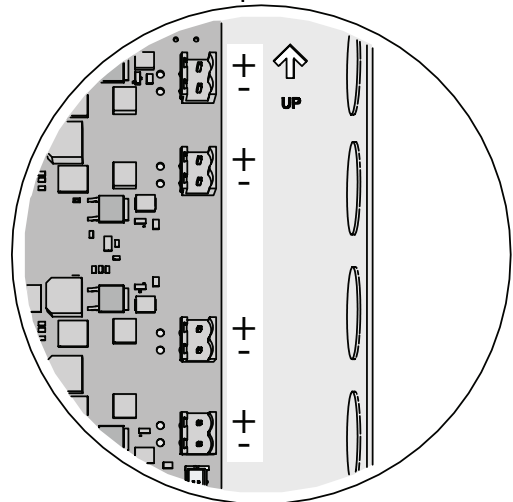

Bridging Output Channels

It is acceptable to bridge multiple output channels together on a D4 Constant Voltage Driver, ganging the maximum output allowed into a single combined output channel. See [Bridge D4 Series Constant Voltage Driver Output Channels on page 46](#) for examples of the configurations made possible by bridging output channels.



Note: This installation technique reduces the number of available output channels. See [Bridge D4 Series Constant Voltage Driver Output Channels on page 46](#).



Note: A maximum of two output channels can be bridged together on a D4 Driver 700 (standard or emergency model).

For more information, see [Bridge D4 Series Constant Voltage Driver Output Channels on page 46](#).

DMX In and DMX Thru

DMX In and DMX Thru cables terminate to RJ45 connectors (all models) or to eight-pin connectors (D4 Driver 350 and 700 standard and emergency models). DMX is installed in a daisy chain topology and includes one pair of wires (data +, data -) plus an ISO ground (common).

RJ45 DMX Termination

All models of D4 Driver have RJ45 receptacles for DMX In and Thru.

ETC recommends Cat5e (or equivalent) minimum 0.2 mm² (24 AWG) conductors terminated to T568B standard. The DMX In and Thru RJ45 connectors on the wall-mount D4 Driver 350 and 700 are not labeled and are interchangeable. Their locations are shown below.

Detail of DMX in and thru plugged into RJ45 connectors in wall-mount drivers

RJ45 Pinout Information

Pin	Description
1	Data +
2	Data -
7&8	ISO ground (common)

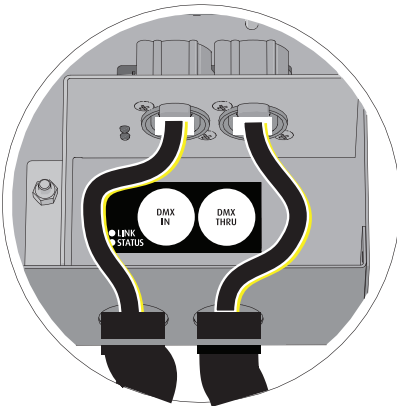

Wall-Mount D4 Driver 150
(Wall-Mount D4 Emergency Driver 150 is similar.)

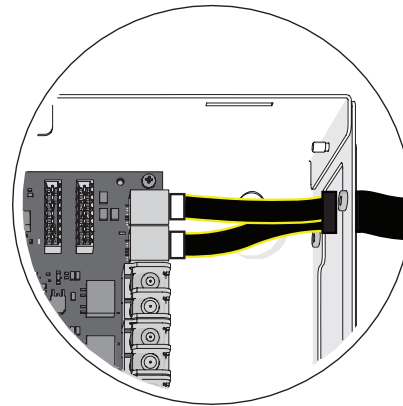

Wall-Mount D4 Driver 350 or 700
(Wall-Mount D4 Emergency Driver 350 or 700 is similar.)



Note: D4 drivers are not self-terminating. You must terminate the last driver in line with a DMX terminator plug in the RJ45 Thru receptacle. To purchase an RJ45 terminator, please contact your ETC customer service representative and request part number N4086.

DMX Termination to Eight-Position Connectors

D4 Driver 350 and 700 standard and emergency models have eight-pin headers for DMX In and Thru in addition to the RJ45 receptacles described in the previous section.

Follow the DMX termination kit instructions provided with the product to terminate the control wiring.



Note: Total length of Belden 9729 should not exceed 500 m (1640 ft) between the control source and the D4 Driver.

D4 Driver 150 Current Configuration



Note: Do not change the switch settings on a D4 Constant Voltage (CV) model driver.

Constant Current (CC) D4 Driver 150 models can be configured for 400 mA or 600 mA output using the four switch blocks shown in the illustration of the [Wall-Mount Driver Wiring Overview on page 16](#).

Outputs

Each of the four switch blocks controls one output.

- Switch block S1 controls LED1.
- Switch block S2 controls LED2.
- Switch block S3 controls LED3.
- Switch block S4 controls LED4.

Switch Functions

Each switch block has six switches.



Note: Do not change the switch 1 settings on a D4 Constant Voltage (CV) model driver.

- Switch 1 sets the current output threshold.
ON = 400 mA, OFF = 600 mA.
- Switches 2 through 5 control the DMX channel assigned to the output.
- Switch 6 enables emergency functionality.

Switches 2 through 5 are factory set to allow each output to be controlled by an individual DMX address. ETC recommends leaving the DMX channel switches (positions 2 through 5) at their factory settings and using the ArcSystem Configuration Software or RDM settings to control the behavior of each output.



Note: ArcSystem D4 Drivers are factory configured for 600 mA output for compatibility with ArcSystem Pro One-Cell and One-Cell Small luminaires. If you power a One-Cell or One-Cell Small luminaire from a D4 output channel that is configured for 400 mA, the output of the luminaire may be dim.



Note: If you set an output on a non-emergency driver to emergency operation, the output will remain at full (or their configured emergency behavior) because there is no normal/sense input to the driver.

Chapter 4

D4 Series Rack-Mount Driver Installation

This section provides information on how to install rack-mount D4 series constant voltage drivers. Up to 32 drivers can be installed on one hard-wired line of DMX.

Electrical and Wiring Specification



WARNING: Circuits that are installed without an accessible power disconnect device cannot be serviced or operated safely.

AVERTISSEMENT : Il est imprudent d'utiliser ou de réparer les circuits installés sans qu'un dispositif de déconnexion de l'alimentation ne soit accessible.

The rack-mount D4 Driver accepts 100–240 VAC, 50/60Hz. Emergency models only: requires normal sense and maintained (emergency) input power. Wire and terminal specifications are the same for all rack-mount drivers.



Note: Minimum 2.5 mm² (14 AWG) output wire size is recommended with D4 CV drivers. See etconnect.com/compatibility and contact Systems for assistance with voltage drop calculations based on power required and run length.

Wire and Terminal Specifications

Terminal / Connector	Wire Range / Specification	Strip Length	Torque Rating
100–240 V Power Input	power cord(s) provided		<ul style="list-style-type: none">• standard models: not applicable• emergency models: may depend on installation
24 V Power Output, four two-position screw terminal connectors, provided	2.5 mm ² (14–12 AWG) Follow Class 1 wiring methods.	7 mm (1/4 in)	0.5–0.6 Nm (4.4–5.3 in-lb)
DMX In/Thru RJ45 Connectors	Cat5e (or equivalent) minimum 0.2 mm (24 AWG) conductors terminated to T568B standard		



Note: All output channels have onboard electronic overload protection. See [Overload Protection on page 45](#).

Prepare for Rack-Mount Installation

Rack-mounted drivers must be installed in a rack in a horizontal flat orientation. Rack-mounted drivers install into a standard 19-inch rack enclosure. One D4 Driver requires one unit (1U) of rack space.

Rack-Mounting Safety

- **Installation Location:** Install the rack in a location where it will not readily be subjected to tampering by unauthorized personnel.
- **Elevated Operating Ambient:** If the D4 Driver is installed in a closed or multi-unit rack assembly, the operating ambient temperature of the rack environment may elevate above the room ambient. Do not operate the device in an enclosed environment above 40°C (104°F).
- **Reduced Air Flow:** When installing the D4 Driver in an equipment rack, the rack must be vented and have adequate airflow to maintain an operating temperature below 40°C (104°F).
- **Mechanical Loading:** Only mount the D4 Driver in an equipment rack using the included ETC rack-mount hardware. Mount in a horizontal orientation to ensure even mechanical loading in the rack, avoiding hazardous or dangerous loading conditions.
- **Circuit Overloading:** When installing the D4 Driver in an equipment rack, consider the connection of the equipment to the rack or power source to avoid overloading the rack circuit or supply wiring. Consider the rack or power distribution in the equipment rack during installation.
- **Reliable Grounding:** Maintain reliable grounding of the rack-mounted equipment. Give particular attention to any supply connections other than direct connections to the branch circuit (for example, the use of power strips).

Terminate Wiring



Rack-Mount D4 Driver 350

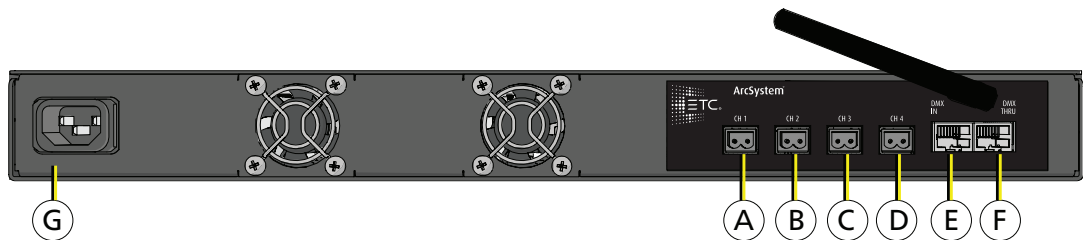

Rack-Mount D4 Driver 700

A	Output channel "CH 1 "	E	"DMX In "
B	Output channel "CH 2 "	F	"DMX Thru "
C	Output channel "CH 3 "	G	Power input
D	Output channel "CH 4 "		

Power Input Wiring

1. Ensure power to the rack is off.
2. Connect the AC input to the AC power source using the provided power input cord.

Output Wiring to Fixture

D4 Series rack-mount drivers have two-pin terminal outputs that can be used to provide power and data to other fixtures.



Note: *Power wiring should only be installed and terminated by a qualified electrician and should follow standard wiring installation practices.*

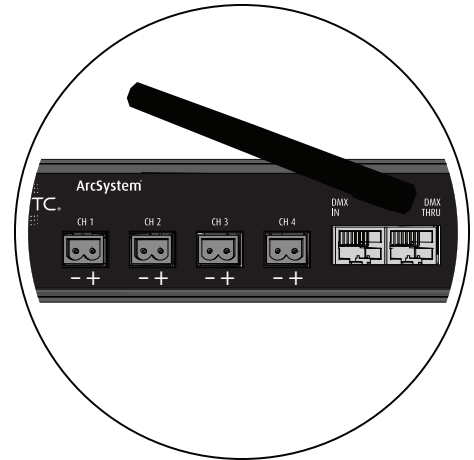

1. Make sure rack power is off.
2. See [Wire and Terminal Specifications on page 23](#) for specification of wire, strip length, and terminal torque ratings. Prepare the wires accordingly.
3. Terminate the positive and negative wires from the constant-voltage load to a terminal output.
 - a. Run wiring through conduit from the constant-voltage load to the rack and route it to the D4 Driver output terminals. Output channels are labeled CH1, CH2, CH3, CH4.
 - b. Loosen the terminal screws on the provided two-position screw-terminal connector.
 - c. Wire the positive and negative wires from the constant-voltage load to the connector, securing each terminal screw onto the wire.
 - d. Tug gently on the wires to ensure they are secure.
 - e. Insert the connector into a two-pin output channel receptacle on the back of the driver.

Bridging Output Channels

It is acceptable to bridge multiple output channels together on a D4 Constant Voltage Driver, ganging the maximum output allowed into a single combined output channel. See [Bridge D4 Series Constant Voltage Driver Output Channels on page 46](#) for examples of the configurations made possible by bridging output channels.



Note: *This installation technique reduces the number of available output channels. See [Bridge D4 Series Constant Voltage Driver Output Channels on page 46](#).*



Note: *A maximum of two output channels can be bridged together on a D4 Driver 700 (standard or emergency model).*

For more information, see [Bridge D4 Series Constant Voltage Driver Output Channels on page 46](#).

DMX In and DMX Thru

DMX In and DMX Thru cables terminate to RJ45 connectors. DMX is installed in a daisy chain topology and includes one pair of wires (data +, data -) plus an ISO ground (common).

RJ45 Pin	Description
1	data +
2	data -
7 & 8	ground

Terminate DMX In and Thru

ETC recommends Cat5e (or equivalent) minimum 0.2 mm² (24 AWG) conductors terminated to T568B standard.



Note: *D4 drivers are not self-terminating. You must terminate the last driver in line with a DMX terminator plug in the RJ45 Thru receptacle. To purchase an RJ45 terminator, please contact your ETC customer service representative and request part number N4086.*

Chapter 5

One-Cell Luminaire Installation

This chapter provides information on how to install ArcSystem Pro One-Cell luminaires in a standard ArcSystem installation.

Installing One-Cell Recessed Luminaires

The installation procedure is similar for all recessed one-cell luminaires (fixed and adjustable). For Pro One-Cell yoke-mounted luminaires, continue on to [Installing One-Cell Yoke-Mounted Luminaires on the next page](#).



WARNING: ArcSystem Pro One-Cell fixtures and drivers are NON-IC rated and therefore NOT suitable for installation in direct contact with combustible materials or thermal insulation.

DO NOT INSTALL INSULATION WITHIN 76 mm (3 in) OF ANY PART OF THE FIXTURE OR DRIVER.

AVERTISSEMENT : Les lampes Pro One-Cell et les drivers ArcSystem sont classés NON-IC, ils ne conviennent donc PAS pour une installation en contact direct avec des matières combustibles ou une isolation thermique.

NE PAS INSTALLER D'ISOLATION À MOINS DE 76 mm (3 po) DE TOUTE PARTIE DE LA LAMPE OU DU DRIVER (DISPOSITIF ÉLECTRONIQUE DE PUISSANCE).



WARNING: Adjustable ArcSystem Pro One-Cell fixtures and adjustable ArcSystem Pro One-Cell Small fixtures are suitable for Non-Fire Rated installations ONLY.

AVERTISSEMENT : Les lampes Pro One-Cell ArcSystem réglables et Pro One-Cell Small ArcSystem réglables sont parfaites UNIQUEMENT pour les installations sans indice de résistance au feu.



Note: Make sure that the flexible electrical supply can extend through the ceiling opening so that the driver and luminaire can be inspected and serviced when needed.

1. Fold both retaining clips towards the luminaire body.
2. Place the luminaire through hole.
3. Release the clips, securing the luminaire in place.
4. When applicable, rotate the luminaire so it is roughly focused to its final resting position. This will assist in final focus procedures.

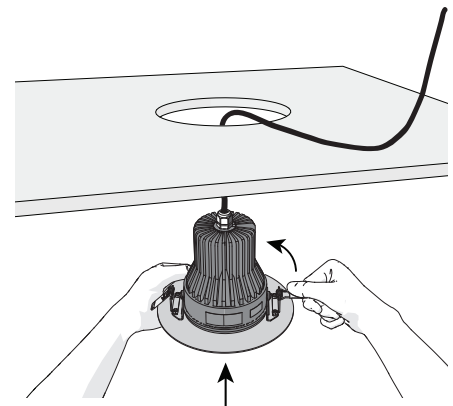

Installing One-Cell Yoke-Mounted Luminaires

1. Attach a C-clamp or other mounting hardware (not provided) to the yoke of the luminaire.
2. Attach the luminaire to a pipe or other approved mounting device.

Chapter 6

Emergency System One-Cell Installation

With the exception of power input terminations, ArcSystem emergency system installation requirements are the same as those of the standard ArcSystem. Complete the appropriate steps for your installation, referencing the following sections for any additional installation details before wiring the power:

- [Preparing the Ceiling for Recessed Luminaires on page 11](#)
- [D4 Series Wall-Mount Driver Installation on page 13](#) or [D4 Series Rack-Mount Driver Installation on page 23](#)

Emergency Driver Power Input Wiring

D4 Emergency Drivers are available for systems requiring emergency lighting control.



Note: *The installation must conform to local and national codes.*

D4 Emergency Drivers require two branch circuit power input connections, normal sense and maintained (emergency).

- Maintained (emergency) provides constant power to the D4 Driver regardless of the state, enforcing the ability to maintain a lights on condition when needed. The power source must be connected to an emergency branch circuit with an upstream UL1008 automatic transfer switch.
- Normal sense detects when normal power is present. In the event of a normal power failure, the D4 Driver will force all output channels on the D4 Driver to full (100%). Any control of the connected output channels will be unavailable until normal power has been restored.

Wall-Mount Emergency Drivers

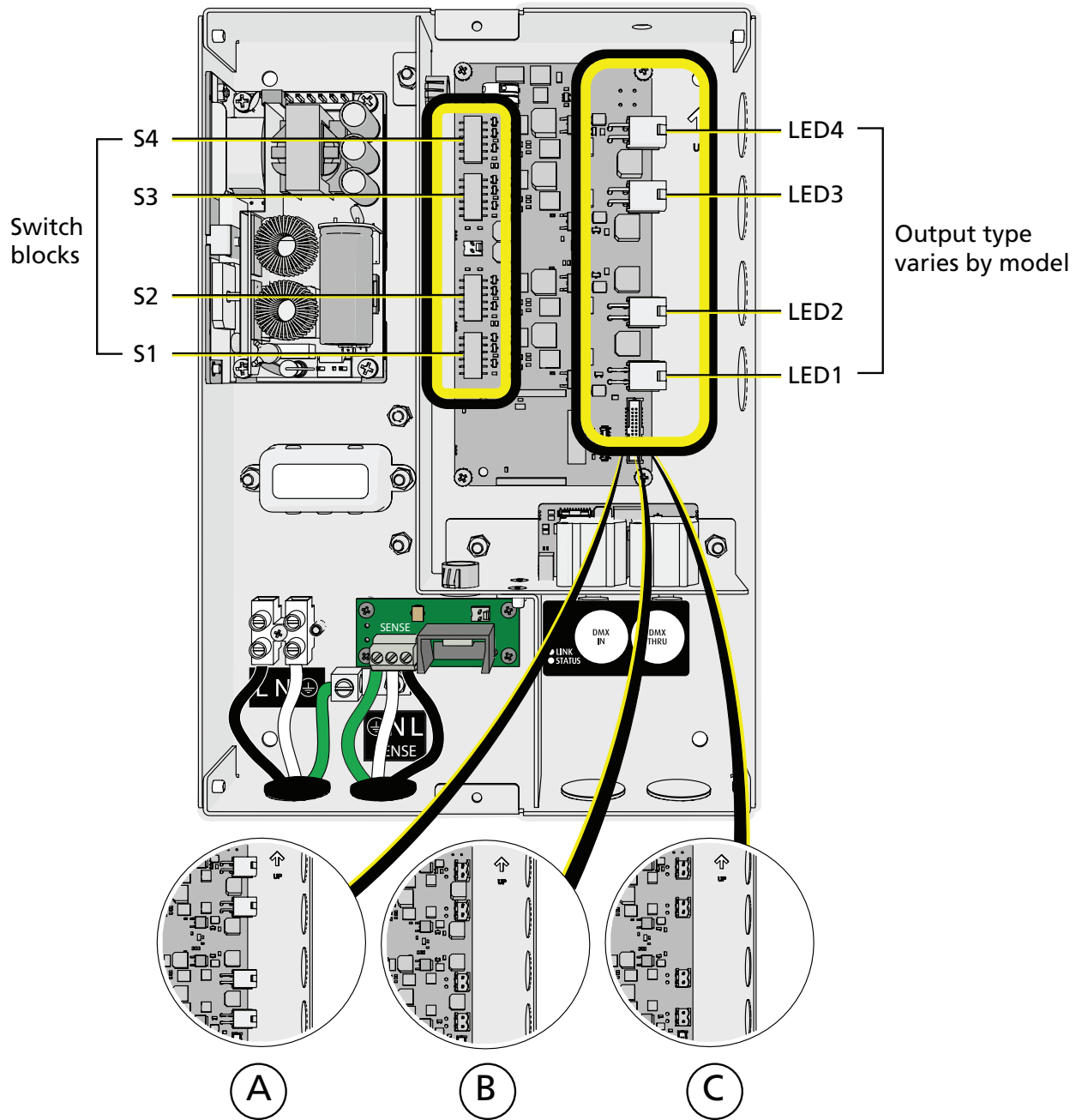

D4 Emergency Driver

A	Constant Current with Molex connectors
B	Constant Current with terminal outputs
C	Constant Voltage with terminal outputs

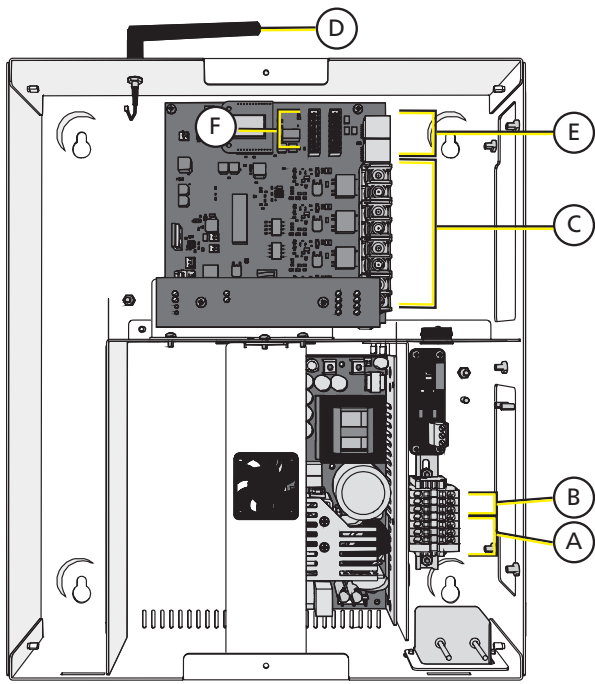

D4 Emergency Driver 350

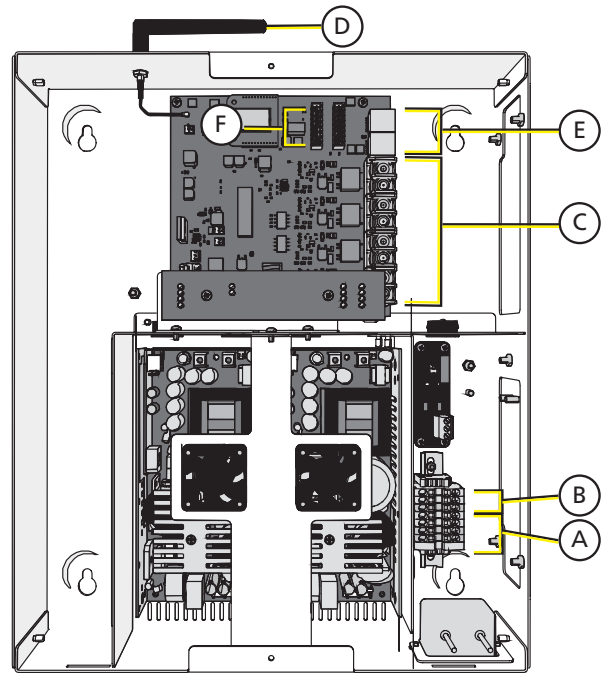

D4 Emergency Driver 700

A	Maintain (emergency) power input
B	Sense (normal sense) power input
C	Output channels
D	Antenna*
E	DMX input and thru (RJ45)
F	DMX input and thru (eight-pin terminal blocks)†

*The antenna is not present on RDM models.

†Eight-pin terminal blocks are not present on D4 Driver 150.

Wall-Mount Emergency Driver Installation



CAUTION: RISK OF SHOCK AND FIRE - This unit has more than one power supply connection point. To reduce the risk of electric shock disconnect both the branch circuit-breakers or fuses and emergency power supplies before servicing.

ATTENTION : RISQUE D'INCENDIE ET DE CHOC - Cet appareil possède plusieurs points de connexion d'alimentation. Pour réduire le risque de choc électrique déconnecter les disjoncteurs de dérivation ou les fusibles et les alimentations de secours avant l'entretien.



CAUTION: Service by qualified personnel only. De-energize before opening.

ATTENTION : Service par du personnel qualifié uniquement. Hors tension avant d'ouvrir.

With the exception of power input terminations, Wall-Mount D4 Emergency Driver installation requirements are the same as those of the standard Wall-Mount D4 Driver. Complete the installation as follows, referencing these sections for installation details:

- Review [Prepare for Wall-Mount Installation on page 15](#)
- Review [Electrical and Wiring Specification on page 13](#)
- Complete [Wall-Mount the Driver on page 15](#)
- Complete [Terminate Normal Sense Input on the facing page](#)
- Complete [Terminate Maintained \(Emergency\) Input on page 35](#)
- Complete [Output Wiring on page 20](#)
- Complete [DMX In and DMX Thru on page 21](#)
- If you are installing a D4 Emergency Driver 150, complete [D4 Driver 150 Current Configuration on page 22](#)

After completing D4 Emergency Driver installation, see [Final Installation and Operation on page 38](#).



Note: Normal and emergency wiring cannot be contained in the same conduit according to NEC 700.10(B).



Note: Use suitable conduit where required by local or national code.

Terminate Normal Sense Input



WARNING: Circuits that are installed without an accessible power disconnect device cannot be serviced or operated safely.

AVERTISSEMENT : Il est imprudent d'utiliser ou de réparer les circuits installés sans qu'un dispositif de déconnexion de l'alimentation ne soit accessible.



Note: Power wiring should only be installed and terminated by a qualified electrician and should follow standard wiring installation practices.

D4 Emergency Driver 150

Connect the mains sense input to a normal branch circuit. See Factory Wire Colors at [D4 Driver 150 on page 18](#).

1. Make sure power is off at the main circuit breaker.
2. Loosen the three screw terminals for NEUTRAL (N), GROUND (⊕), and LINE (L) connections.
3. Insert the ground wire (typically green) into the GROUND (⊕) terminal and tighten the screw.
4. Insert the neutral wire (typically white) into the NEUTRAL (N) terminal and tighten the screw.
5. Connect the line wire (typically black) into the LINE (L) terminal and tighten the screw.
6. Tug gently on the wires to ensure they are secure.

Wall-Mount D4 Emergency Driver 350 or 700

Wall-Mount D4 Emergency Driver 350 and 700 have push-in terminal blocks on the "Sense" and "Maintain" inputs. No tools are required to insert wires into the terminal block. See [Push-In Terminal Blocks on page 19](#) for an illustration of the push-in terminal blocks.

- To install wire, insert the wire into the terminal.
- To remove wire, insert a 3.5 mm flatblade screwdriver into the tool slot next to the wire terminal to release the wire, then pull the wire out of the terminal.

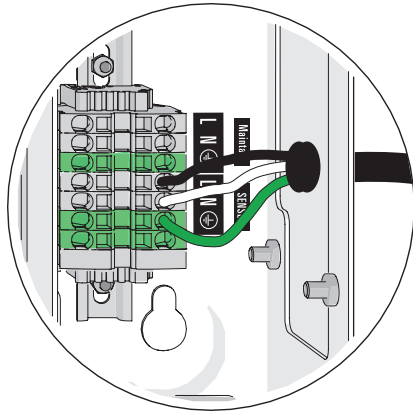

**Wall-Mount
D4 Emergency Driver 350/700
Sense Input Detail**

Factory Wire Colors

Model	Color	Type
North America and Europe	green/yellow	ground/earth
North America	black	line/hot
North America	white	neutral
Europe	brown	live
Europe	blue	neutral

1. Make sure power is off at the main circuit breaker.
2. See [Wire and Terminal Specifications on page 14](#) for specification of wire size and strip length. Prepare the wires accordingly.
3. See [Push-In Terminal Blocks on page 19](#) for general instructions on using the push-in terminal blocks.
4. Insert the ground wire (typically green) into the terminal marked "Sense .
5. Insert the neutral wire (typically white) into the terminal marked "Sense N."
6. Terminate the line (hot) wire (typically black) into the terminal marked "Sense L."
7. Tug gently on the wires to ensure they are secure.

Terminate Maintained (Emergency) Input

D4 Emergency Driver 150



Note: The maintained input in a D4 Series driver is the input labeled "L N ⊕". The D4 sense input is labeled "⊕ N L Sense".

Connect maintained input to a normal/emergency branch circuit with upstream UL 1008 automatic transfer switch. See Factory Wire Colors at [D4 Driver 150 on page 18](#).

1. Loosen the three screw terminals for NEUTRAL (N), GROUND (⊕), and LINE (L) connections.
2. Insert the ground wire (typically green) into the GROUND (⊕) terminal and tighten the screw.
3. Insert the neutral wire (typically white) into the NEUTRAL (N) terminal and tighten the screw.
4. Connect the line wire (typically black) into the LINE (L) terminal and tighten the screw.
5. Tug gently on the wires to ensure they are secure.

Wall-Mount D4 Emergency Driver 350 and 700

Wall-Mount D4 Emergency Driver 350 and 700 have push-in terminal blocks on the "Sense" and "Maintain" inputs. No tools are required to insert wires into the terminal block. See [Push-In Terminal Blocks on page 19](#) for an illustration of the push-in terminal blocks.

- To install wire, insert the wire into the terminal.
- To remove wire, insert a 3.5 mm flatblade screwdriver into the tool slot next to the wire terminal to release the wire, then pull the wire out of the terminal.

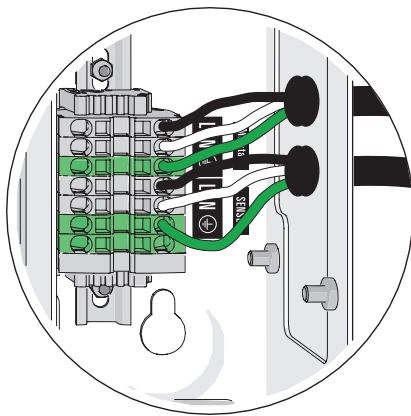

Wall-Mount
D4 Emergency Driver 350/700
Sense and Maintained Input Detail

Factory Wire Colors

Model	Color	Type
North America and Europe	green/yellow	ground/earth
North America	black	line/hot
North America	white	neutral
Europe	brown	live
Europe	blue	neutral

1. Make sure power is off at the main circuit breaker.
2. See [Wire and Terminal Specifications on page 14](#) for specification of wire size and strip length. Prepare the wires accordingly.
3. See [Push-In Terminal Blocks on page 19](#) for general instructions on using the push-in terminal blocks.
4. Insert the ground wire (typically green) into the terminal marked "Maintain ⊕."
5. Insert the neutral wire (typically white) into the terminal marked "Maintain N."
6. Terminate the line (hot) wire (typically black) into the terminal marked "Maintain L."
7. Tug gently on the wires to ensure they are secure.

Rack-Mount Emergency Drivers



Rack-Mount D4 Emergency Driver 350

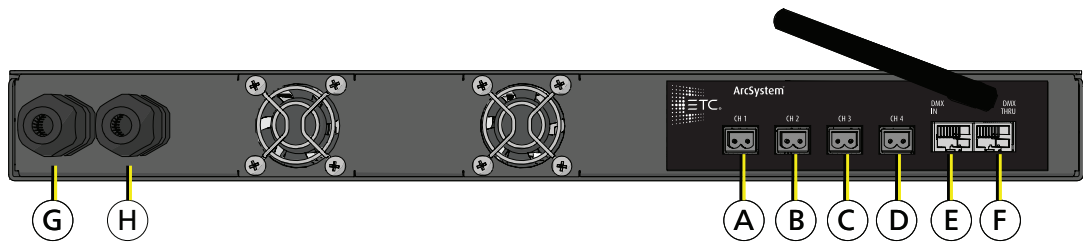

Rack-Mount D4 Emergency Driver 700

A	Output channel "CH 1 "	E	"DMX In "
B	Output channel "CH 2 "	F	"DMX Thru "
C	Output channel "CH 3 "	G	Maintained power input cord (bare end)
D	Output channel "CH 4 "	H	Normal/Sense power input cord (bare end)

Rack-Mount Emergency Driver Installation



WARNING: RISK OF DEATH BY ELECTRIC SHOCK! Before you begin pulling and terminating wire to the ArcSystem Driver enclosure or TX1 Transmitter, make sure the main circuit breaker cabinet or other readily accessible input power disconnect device for the normal power input (and emergency power input when used) is locked out and tagged out.

AVERTISSEMENT : RISQUE DE MORT PAR DÉCHARGE ÉLECTRIQUE! Avant de passer le câblage et de le raccorder au boîtier du driver ArcSystem ou à l'émetteur TX1, s'assurer de la coupure électrique du disjoncteur principal ou d'une autre arrivée électrique pour l'alimentation normale (et l'alimentation de secours lorsqu'elle est utilisée); s'assurer aussi que le disjoncteur ou le dispositif de déconnexion est verrouillé et identifié.

Rack-mount D4 Emergency Drivers sold in North America have hard-wired power input cables with plugs. Rack-mount D4 Emergency Drivers sold outside of North America have hard-wired power input cables with bare ends for direct connection to your maintained/emergency and normal sense power supplies. The cables are labeled near the strain reliefs for Maintained Input and Sense Input.

With the exception of power input terminations, rack-mount D4 Emergency Driver installation requirements are the same as those of the standard rack-mount D4 Driver. Complete the installation as follows, referencing these sections for installation details:

- Review [Electrical and Wiring Specification on page 23](#)
- Review [Prepare for Rack-Mount Installation on page 23](#)
- Connect the Normal/Sense input to the normal sense AC power source using the provided power input cord.
- Connect the Maintained (Emergency) input to the maintained emergency AC power source using the provided power input cord.
- Complete [Output Wiring to Fixture on page 25](#)
- Complete [DMX In and DMX Thru on page 26](#)

After completing D4 Emergency Driver installation, see [Final Installation and Operation on page 38](#).

Chapter 7

Final Installation and Operation

Wireless ArcSystem D1, D1 HO, D2, and D4 drivers and wireless ArcSystem multi-cell luminaires are supplied with a 5 dB antenna providing 90 degree omni-directional coverage. Install this antenna to the antenna receptacle.



Note: *Incorrect installation of recessed luminaires may cause output to turn on and off periodically due to built-in protection against overheating. Leave the lamp on for several hours to check for overheating caused by improper installation. The driver can overheat even if the lamp is off.*

Power Up Procedure

1. Check that luminaire power switch is on, if applicable.
2. Check the DMX control source to ensure proper installation and termination per the manufacturer's instructions.
3. Apply power at the main circuit breaker.

After the power up procedure, the luminaire will light.



Note: *When commissioning a system installation, check all ArcSystem Drivers and multi-cell luminaires to ensure that the latest firmware is present. If the firmware is not up to date, upgrade it following the instructions at [Updating the Luminaire Firmware](#) below.*



Note: *All ArcSystem luminaires are factory set to provide 100% output level. This allows an electrical contractor to check that all products are properly installed and wired. During system commissioning, the certified ETC technician will remove this setting and configure DMX addresses for normal use. During normal use after commissioning is complete, ArcSystem luminaires will light if the DMX Control level is greater than 0.*

Updating the Luminaire Firmware

When commissioning a system installation, check all ArcSystem drivers and multi-cell luminaires to ensure that the latest firmware is present. If the firmware is not up to date, upgrade it following the instructions below for your luminaire type.

Wireless ArcMesh Luminaires

Upgrade luminaire firmware using the ArcSystem Configuration Software. The fixture firmware file and ArcSystem Configuration Software are available for free at etcconnect.com.

RDM Luminaires

Upgrade luminaire firmware using ETC Concert and ETC UpdaterAtor software before commissioning is completed. For more information on UpdaterAtor, download the *UpdaterAtor Software Quick Guide* for free at etcconnect.com.

Commissioning a Wireless ArcSystem

Initial programming of a wireless ArcSystem requires a USB commissioning tool (ARCMCT), and existing hardware such as a laptop or desk top computer that is connected to ArcSystem. This programming will be carried out by an ETC certified technician at the time of system commissioning and training.

The following is a list of procedures included in the configuration process:

- patching groups of luminaires to specific DMX channels
- assigning minimum and maximum dimming levels per group
- assigning power fail/recovery options per group



Note: *To ensure a smoother transition from an emergency state to a standard run state, ETC recommends setting DMX Loss behavior as "Go to Full" on ArcSystem TX1 Transmitters. In the ArcSystem Configuration Software, this setting is at Edit Wireless Gateway>DMX and is called Fade on loss of DMX.*

DMX System Control

ArcSystem with ArcMesh can be installed and controlled over the wireless ArcMesh protocol, hard wired DMX, or a hybrid of the two, making it a great solution for both new construction and retrofit situations.

ArcSystem RDM Systems can be controlled over wired DMX from a lighting console or ETC Concert software. Concert is available for free download at etcconnect.com/Concert.

- ArcSystem is compliant with DMX 512-A (ANSI E1.11-2008 (R2013)).
- DMX loss behavior is hold last look.

For wired DMX installation, each luminaire can be addressed to any one of the 512 DMX addresses up to the maximum device limit of 32 devices on each DMX line. Wireless DMX control requires a TX1 Transmitter and luminaires with the wireless ArcMesh transceiver. For wireless DMX installation, there are up to 64 control channels available. See the *ArcSystem Installation Manual*, available from etcconnect.com.

Channels can be grouped and programmed into presets per the needs of your space. Groups and presets can be recalled through a lighting console or other devices.

Programming groups and presets is done through the configuration tool at time of system commissioning. This programming will be done by an ETC certified technician. For more information see [Commissioning a Wireless ArcSystem above](#).

Both wired and wireless products can be used within a single system. The following graphic shows an example of how a system with wired luminaires, wireless luminaires, and a transmitter may be installed.

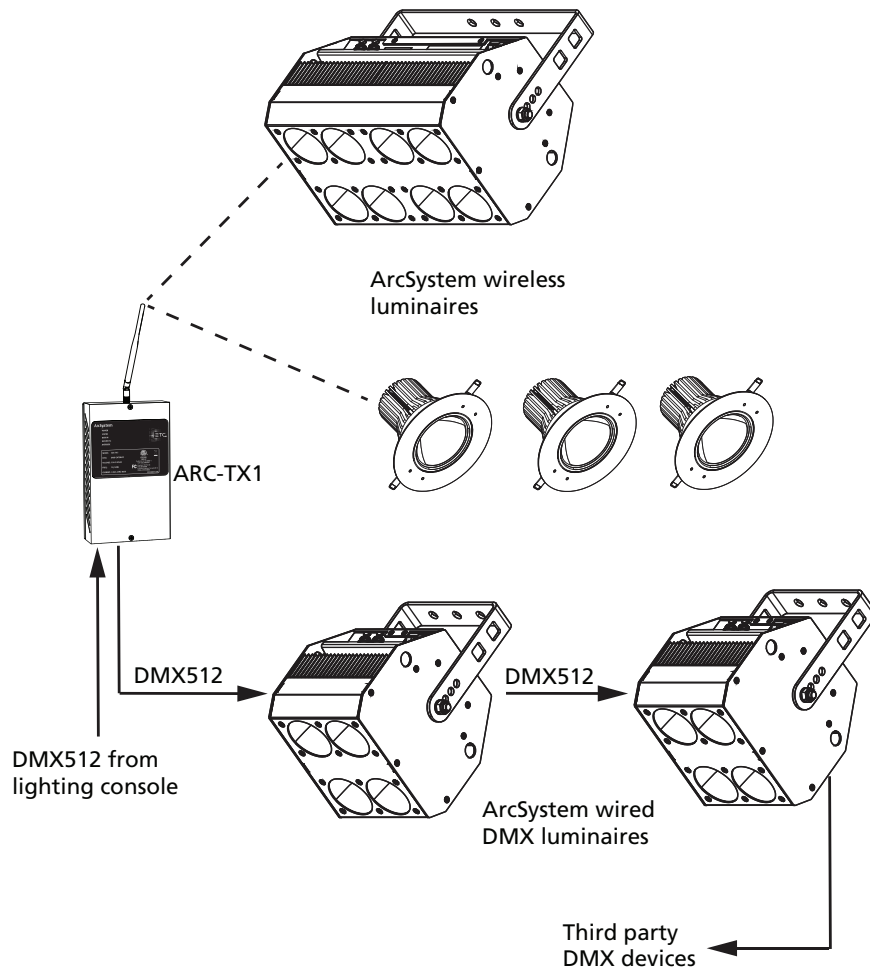

Note: By default the TX1 DMX output is disabled. If you require DMX output from the TX1, you must use the ArcSystem commissioning tool software to add DMX fixtures.

RDM Values

Manufacturer ID: 0x6574 (Electronic Theatre Controls)

Model IDs

Product Type	Description	Model ID
ArcSystem D4 Drivers	Constant Current D4 Driver 150	0x1204
	Constant Current D4 Emergency Driver 150	0x1304
	Constant Voltage D4 Driver 150, D4 Driver 350, and D4 Driver 700 (wall-mount and rack-mount)	0x1205
	Constant Voltage D4 Emergency Driver 150, D4 Emergency Driver 350, and D4 Emergency Driver 700	0x1305

Parameter	RDM PID	Value	Notes
DMX Start Address	0x00F0	Range = 001 to 512	Default is 001. The upper limit for the D4 Series drivers is 508.
DMX Personality	0x00E0	1 or 2	Default is 2. This parameter sets the number of DMX channels available on a D4 Series driver. <ul style="list-style-type: none"> Set to 1 sets DMX personality to multi-channel. Set to 2 sets DMX personality to single-channel.
Identify Device	0x1000	0 for stop identify, 1 for start identify	Set to 1 causes output(s) and LEDs of the unit to blink in a one second on, one second off pattern.
Minimum Level	0x0341	Minimum Level - Increasing: 0 to 255 Minimum Level - Decreasing: 0 to 255	Default is 99%. The luminaire will not accept a Minimum Level that is higher than the Maximum Level. Minimum Level - Increasing and Minimum Level - Decreasing need to be set to the same value.
Maximum Level	0x0342	0 to 255	Default is 100%. The luminaire will not accept a Maximum Level that is lower than the Minimum Level.
Curve	0x0343	1, 2, or 3	<ul style="list-style-type: none"> Set to 1 is the Default Tungsten Curve (aka D04A) Set to 2 is Linear Set to 3 is Square Law
Curve Description	0x0344		Get returns an ASCII text string.
Output Response Time	0x0345	<ul style="list-style-type: none"> 0x01 1000 ms/100 steps 0x02 900 ms/90 steps 0x03 800 ms/80 steps 0x04 700 ms/70 steps 0x05 600 ms/60 steps 0x06 500 ms/50 steps 0x07 400 ms/40 steps 0x08 300 ms/30 steps 0x09 250 ms/25 steps 0x0A 200 ms/20 steps 0x0B 100 ms/10 steps 0x0C 50 ms/5 steps 0x0D 0 ms/0 steps 	Default is 500ms/50 steps. This parameter controls dimming up in level.
Output Response Time Down	0x8030		Default is 500 ms/50 steps. This parameter controls dimming down in level. Set 0x00 to set the Output Response Time Down to the same setting as Output Response Time.
Output Response Time Description	0x0346		Get returns an ASCII text string.
Modulation Frequency	0x0347	<ul style="list-style-type: none"> 1 for 300 Hz 2 for 600 Hz 3 for 1.2 kHz 4 for 19.2 kHz 	Default is 300 Hz.
Modulation Frequency Description	0x0348		Get returns an ASCII text string.
Restore Factory Defaults	0x0090		Set resets the luminaire configuration to default settings.
Software Version Label	0x00C0		Get returns the current software version as an ASCII text string.
Bootloader Version Label	0x00C2		Get returns the current bootloader version as an ASCII text string.

Maintenance



WARNING: RISK OF DEATH BY ELECTRIC SHOCK! Failure to disconnect all power to the system before installation, maintenance, cleaning, or any other system modification could result in serious injury or death.

AVERTISSEMENT : RISQUE DE MORT PAR DÉCHARGE ÉLECTRIQUE! Négliger de débrancher toutes les sources d'alimentation du système avant l'installation, l'entretien, le nettoyage ou toute autre modification du système peut causer des blessures graves ou la mort.

De-energize main feed to ArcSystem and follow appropriate Lockout/Tagout procedures as mandated by NFPA 70E. It is important to note that electrical equipment such as breaker panels can present an arc flash hazard if improperly serviced. This is due to the high amounts of short-circuit current available on the electrical supply to this equipment. Any work must comply with OSHA Safe Working Practices.



WARNING: RISK OF ELECTRIC SHOCK! Circuits that are installed without an accessible power disconnect device cannot be serviced or operated safely.

AVERTISSEMENT : RISQUE DE DÉCHARGE ÉLECTRIQUE! Il est imprudent d'utiliser ou de réparer les circuits installés sans qu'un dispositif de déconnexion de l'alimentation ne soit accessible.



WARNING: RISK OF ELECTRIC SHOCK! The light sources in this luminaire are not user-replaceable, and must be replaced only by a qualified technician. Contact ETC Customer Support for assistance.

AVERTISSEMENT : RISQUE DE DÉCHARGE ÉLECTRIQUE! Les sources lumineuses de ce projecteur ne sont pas remplaçables par l'utilisateur et doivent être remplacées seulement par un technicien qualifié. Contactez le service client ETC pour obtenir de l'assistance.



WARNING: Disconnect the fixture from power and DMX and allow it to cool before performing any cleaning and maintenance.

AVERTISSEMENT : Débrancher la lampe de son alimentation et du DMX et la laisser refroidir avant d'effectuer un nettoyage ou un entretien.



CAUTION: *Check for excessive dust or debris in the heat-dissipating fins around the entire luminaire enclosure. Clean using compressed air or a soft cloth. Keeping the components of the enclosure clean facilitates efficient cooling and extends LED longevity.*

NEVER spray liquids into the luminaire.

NEVER spray compressed air into a luminaire that is powered-up.

A can of compressed air or oil-free air from an air compressor set at a low setting can be used to blow through the vent holes and remove dust or other debris. Dust buildup can cause overheating and premature shutdown.

All components can be cleaned using compressed, oil-free air as described above or a clean micro-fiber cloth. The use of any liquid cleaning solution is not recommended.

Inspect all mounting hardware for wear and, if necessary, clean using compressed, oil-free air or a soft, lint-free cloth.

Emergency Operation and Test

It is important to test ArcSystem emergency systems regularly because they are life safety devices. **NOT SELF-TESTING PER ANSI/NFPA 101 - This equipment is not self-testing in conformance with the Life Safety Code, ANSI/NFPA 101. ANSI/NFPA 101 Life Safety Code requires testing of life safety devices every 30 days.**

To test the emergency functionality of this device, disconnect the sense circuit.



WARNING: RISK OF DEATH BY ELECTRIC SHOCK! Failure to disconnect all power to the system before installation, maintenance, cleaning, or any other system modification could result in serious injury or death.

AVERTISSEMENT : RISQUE DE MORT PAR DÉCHARGE ÉLECTRIQUE! Négliger de débrancher toutes les sources d'alimentation du système avant l'installation, l'entretien, le nettoyage ou toute autre modification du système peut causer des blessures graves ou la mort.

De-energize main feed to ArcSystem and follow appropriate Lockout/Tagout procedures as mandated by NFPA 70E. It is important to note that electrical equipment such as breaker panels can present an arc flash hazard if improperly serviced. This is due to the high amounts of short-circuit current available on the electrical supply to this equipment. Any work must comply with OSHA Safe Working Practices.



CAUTION: *This equipment has more than one power supply connection point. To reduce the risk of electric shock, disconnect both the branch circuit-breakers or fuses and emergency power supplies before servicing.*

ATTENTION : *Cet équipement possède plusieurs points de connexion d'alimentation. Pour réduire le risque d'électrocution, débranchez les disjoncteurs de dérivation ou les fusibles et les alimentations de secours avant de procéder à l'entretien.*

Test the ArcSystem emergency system as described:

1. Turn off power at the normal circuit breaker.
2. Test the system per ANSI/NFPA 101 Life Safety Code.

Troubleshooting

LED Indicators

D4 Driver 350 and 700 wall-mount and rack-mount, standard and emergency models have LED indicators. The Status LED will blink or stay solid for short periods during normal operation. See the table below for LED behavior.

Power LED	On: power is present Off: power is not present
EM Active (emergency models only)	On: D4 Driver has lost its normal sense input and is currently in emergency override state - all output channels are on at 100%.
PSU 1 Fault	D4 Driver 700 and D4 Emergency Driver 700 only On: power supply 1 has a fault. Contact ETC Technical Services for assistance.
PSU 2 Fault	D4 Driver 700 and D4 Emergency Driver 700 only On: power supply 2 has a fault. Contact ETC Technical Services for assistance.
DMX In	Slow Flash (wireless operation): normal operation. DMX broadcast is being received and DMX data is not changing. Solid On (wireless operation): active DMX signal is being received Solid On (wired DMX): DMX is present
Status	Steady blinking: processor is operating normally Solid On: system is responding to DMX instruction Solid On when no DMX command is being sent: there is a processor fault. Contact ETC Technical Services for assistance.
Channel OK LEDs	Solid On with no Channel Limit LEDs lit: channel is outputting normally Off: main power to D4 Driver is off. Steady blinking, alternating with Channel Limit LED: channel output exceeded the trip limit. Loads will flash. See Overload Protection on the facing page . Contact ETC Technical Services for assistance.
Channel Limit LEDs	Solid on: channel output exceeded the warning limit. See Overload Protection on the facing page . Contact ETC Technical Services for assistance. Steady blinking, alternating with Channel OK LED: channel output exceeded the trip limit. Loads will flash. See Overload Protection on the facing page . Contact ETC Technical Services for assistance.



Note: For more information about warning and trip behavior, see [Overload Protection on the facing page](#).

Overload Protection

D4 series drivers have two types of maximum output limit: warning and trip. Contact ETC technical services for assistance with warning and fault conditions.

Warning

On D4 Driver 350 and 700 models only, the "Channel OK" LED will remain solid on and the Channel Limit LED will light if the current drawn on any channel exceeds the warning limits.

Trip

On all models, loads will flash if the current drawn on any output channel exceeds the trip limits. The protection circuit retries the connection every 1 second until the trip condition is resolved or the main circuit breaker supplying power to the D4 Driver is shut off. If all channels draw current below the trip limits, the circuit will reconnect and lamps will stop flashing.

Trip LED behavior

On D4 Driver 350 and 700 models only, the "Channel OK" LED and Channel Limit LED will alternate flashing if the current drawn on any output channel exceeds the trip limits. Channel Limit LEDs will turn off and "Channel OK" LEDs will turn solid on when the circuit reconnects.

Warning Limits and Trip Limits

Driver Description	Warning Limits				Trip Limits			
	Single Channel	Number of Channels Per Bridge			Single Channel	Number of Channels Per Bridge		
		2	3	4		2	3	4
D4 Driver 150 or D4 Emergency Driver 150	NO WARNING OR TRIP LEDs If circuits are overloaded on a D4 Driver 150, output may appear dim or loads may not light. Contact ETC Technical Services for assistance.							
Wall-Mount D4 Driver or D4 Emergency Driver 350	3.0 A	5.8 A	8.1 A	9.8 A	3.6 A	7.0 A	9.8 A	12.0 A
Rack-Mount D4 Driver or D4 Emergency Driver 350	3.0 A	5.6 A	8.6 A	11.0 A	3.6 A	6.7 A	10.6 A	13.0 A
Wall-Mount D4 Driver or D4 Emergency Driver 700	6.1 A	12.0 A	NOT SUPPORTED		7.1 A	14.2 A	NOT SUPPORTED	
Rack-Mount D4 Driver or D4 Emergency Driver 700	6.1 A	11.0 A	NOT SUPPORTED		7.1 A	13 A	NOT SUPPORTED	

See [Bridge D4 Series Constant Voltage Driver Output Channels on page 46](#) for more information about bridging channels.

Appendix A

Bridge D4 Series Constant Voltage Driver Output Channels

It is acceptable to bridge multiple output channels together on an ArcSystem D4 Series Constant Voltage Driver, ganging the maximum output allowed into a single combined output channel. See below for examples of the configurations made possible by bridging output channels.



Note: *A maximum of two output channels can be bridged together on a D4 Driver 700 (standard or emergency model).*



Note: *Do not bridge outputs on a constant current driver. Verify that your driver is an ArcSystem D4 Series Constant Voltage Driver by looking for one of the following model numbers on the cover:*

- ARCPD4DCV
 - ARCPED4DCV
 - ARCPD4DCV24350TMR
 - ARCPED4DCV24350TMR
 - ARCPD4DRDMCV24350TMR
 - ARCPED4DRDMCV24350TMR
 - ARCPD4DCV24350TMW
 - ARCPED4DCV24350TMW
 - ARCPD4DRMDCV24350TMW
 - ARCPED4DRDMCV24350TMW
 - ARCPD4DCV24700TMR
 - ARCPED4DCV24700TMR
 - ARCPD4DRDMCV24700TMR
 - ARCPED4DRDMCV24700TMR
 - ARCPD4DCV24700TMW
 - ARCPED4DCV24700TMW
 - ARCPD4DRDMCV24700TMW
 - ARCPED4DRDMCV24700TMW
-



WARNING: RISK OF DEATH BY ELECTRIC SHOCK! Before you begin pulling and terminating wire to the ArcSystem Driver enclosure or TX1 Transmitter, make sure the main circuit breaker cabinet or other readily accessible input power disconnect device for the normal power input (and emergency power input when used) is locked out and tagged out.

AVERTISSEMENT : RISQUE DE MORT PAR DÉCHARGE ÉLECTRIQUE! Avant de passer le câblage et de le raccorder au boîtier du driver ArcSystem ou à l'émetteur TX1, s'assurer de la coupure électrique du disjoncteur principal ou d'une autre arrivée électrique pour l'alimentation normale (et l'alimentation de secours lorsqu'elle est utilisée); s'assurer aussi que le disjoncteur ou le dispositif de déconnexion est verrouillé et identifié.



WARNING: You must use an approved wiring kit provided by ETC. Do not bridge output channels with unapproved wire or hardware.

AVERTISSEMENT : Vous devez utiliser un kit de câblage agréé et fourni par ETC. Ne pontez pas les circuits de sortie avec des fils ou du matériel non agréés.



Note: Power wiring should only be installed and terminated by a qualified electrician and should follow standard wiring installation practices.



Note: This installation technique reduces the number of available output channels.

Bridge Specifications

D4 Series Driver Model	Bridge Configuration	Max. Current on new Channel	Max. Power on new Channel
D4 Driver 150 or D4 Emergency Driver 150	2 bridged into 1	3.25 A	78 W
	3 bridged into 1	4.5 A	108 W
	4 bridged into 1	5.75 A	138 W
Wall-Mount D4 Driver 350 or D4 Emergency Driver 350	2 bridged into 1	5.8 A	140 W
	3 bridged into 1	8.25 A	198 W
	4 bridged into 1	11 A	264 W
Rack-Mount D4 Driver 350 or D4 Emergency Driver 350	2 bridged into 1	5.6 A	134 W
	3 bridged into 1	8.6 A	206 W
	4 bridged into 1	11 A	264 W
Wall-Mount D4 Driver 700 or D4 Emergency Driver 700	2 bridged into 1	12 A	288 W
	3 bridged into 1	NOT SUPPORTED	
	4 bridged into 1		
Rack-Mount D4 Driver 700 or D4 Emergency Driver 700	2 bridged into 1	11 A	264 W
	3 bridged into 1	NOT SUPPORTED	
	4 bridged into 1		



Note: All output channels have on-board overload protection. See [Overload Protection on page 45](#).



Note: The installation site must consider power requirements at the fixture and allow for voltage drop with distance. See [Voltage Drop on the next page](#).

Voltage Drop

Consult the manufacturer's documentation for your load to find the minimum voltage required for operation. Voltage drop calculations vary by project and are based on the type, length, and gauge of wire used between the D4 Driver and load. Contact a qualified electrician or ETC technical services for further information.

Wall-Mount Bridging Kits

1. 7490K2002 bridging kit for D4 Driver 150 and D4 Emergency Driver 150
 - for bridging combinations of 2, 3, or 4 channels
 - four 3-position WAGO® connectors, each with two attached wires, pre-stripped
 - two 5-position WAGO connector with four attached wires, pre-stripped
2. 7490K2003 bridging kit for D4 Driver 350 and D4 Emergency Driver 350
 - for bridging combinations of 2, 3, or 4 channels
 - four 3-position WAGO connectors, each with two attached wires terminated with forks
 - two 5-position WAGO connector with four attached wires terminated with forks
3. 7490K2004 bridging kit for D4 Driver 700 or D4 Emergency Driver 700
 - for bridging combinations of 2 channels
 - four 3-position WAGO connectors, each with two attached wires terminated with forks

Rack-Mount Bridging Kits

1. 7490K2005 bridging kit for rack-mount D4 Driver 350
 - for bridging combinations of 2, 3, or 4 channels
 - four 3-position WAGO connectors, each with two attached wires, pre-stripped
 - two 5-position WAGO connector, with four attached wires, pre-stripped
2. 7490K2006 bridging kit for rack-mount D4 Driver 700
 - for bridging combinations of 2 channels
 - four 3-position WAGO connectors, each with two attached wires, pre-stripped

Output Channel Control Switches

Each output channel on the D4 Driver is controlled by a switch block (S1–S4, shown below). Switch positions 2–5 are factory set to allow individual control of each output. In order to bridge channels together, you must adjust the positions of switches 2–5.

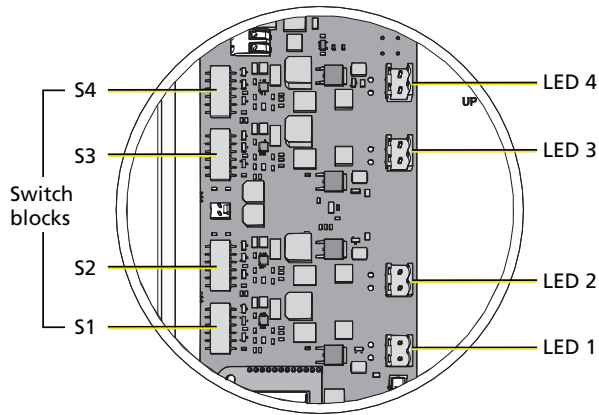

Wall-Mount D4 Driver 150

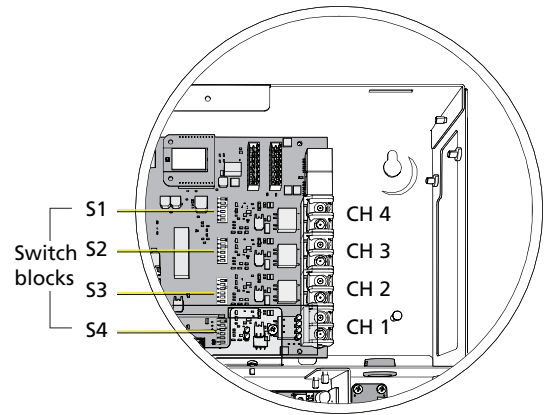

Wall-Mount D4 Driver 350/
Wall-Mount D4 Driver 700

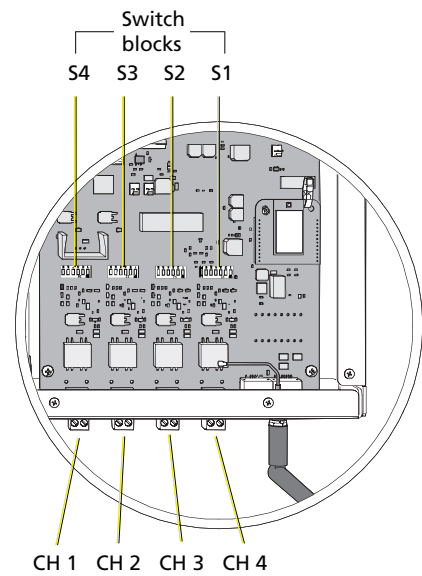

Rack-Mount D4 Driver 350/
Rack-Mount D4 Driver 700

Switch Blocks

Each of the four switch blocks controls one output channel.

- Switch block S1 controls the output channel labeled "LED 1" on D4 Driver 150 or "CH 4" on D4 Driver 350 and 700.
- Switch block S2 controls the output channel labeled "LED 2" on D4 Driver 150 or "CH 3" on D4 Driver 350 and 700.
- Switch block S3 controls the output channel labeled "LED 3" on D4 Driver 150 or "CH 2" on D4 Driver 350 and 700.
- Switch block S4 controls the output channel labeled "LED 4" on D4 Driver 150 or "CH 1" on D4 Driver 350 and 700.

Switch Functions

There are six switches on each switch block.

- Switch positions 1 and 6 are factory set and should not be adjusted.
- Switch positions 2 through 5 are factory set to allow each output to be controlled individually. You must adjust these switches on the switch block that controls each output channel that you want to bridge.

D4 Driver 150 Factory Settings for Individual Output Channel Control

Switch Block (Output)	Switch Positions					
	1	2	3	4	5	6
S1 (LED 1)	Do not adjust from factory setting	ON	OFF	OFF	OFF	Do not adjust from factory setting
S2 (LED 2)		OFF	ON	OFF	OFF	
S3 (LED 3)		OFF	OFF	ON	OFF	
S4 (LED 4)		OFF	OFF	OFF	ON	

D4 Driver 350 and 700 Factory Settings for Individual Output Channel Control

Switch Block (Output)	Switch Positions					
	1	2	3	4	5	6
S4 (CH 1)	Do not adjust from factory setting	ON	OFF	OFF	OFF	Do not adjust from factory setting
S3 (CH 2)		OFF	ON	OFF	OFF	
S2 (CH 3)		OFF	OFF	ON	OFF	
S1 (CH 4)		OFF	OFF	OFF	ON	

Setting Switches 2 Through 5 for Bridged Output Channels



Note: *Each output channel that you want to bridge must have the same setting for switch positions 2–5 as the other output channels in the bridge. Output channels that are electrically connected (bridged) with different switch settings may have reduced capacity.*



Note: *If you are using a wireless D4 Driver with ArcMesh, you must also set bridged outputs to the same DMX address in the ArcSystem Configuration Software so that they function as one output channel.*

All output channels with the same settings on switch positions 2–5 will respond to the same DMX address even if they are not electrically connected (bridged).

Example Bridge Configurations

All Four Output Channels Bridged

Bridging four output channels can be done as shown below for maximum load capacity on one circuit and control on output channel 1. The bridged circuit can be assigned to any output channel as long as all four switch blocks (S1–S4) are set the same. The illustration and table below show all four output channels bridged together to form bridged output channel 1.

Detail of four output channels bridged into one.

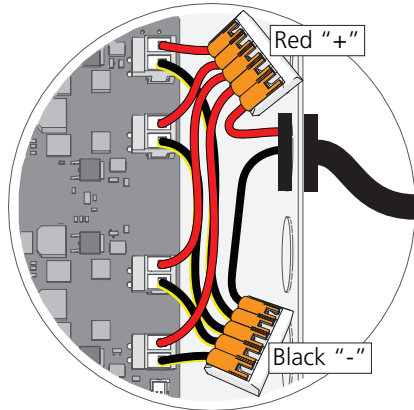

Wall-Mount D4 Driver 150

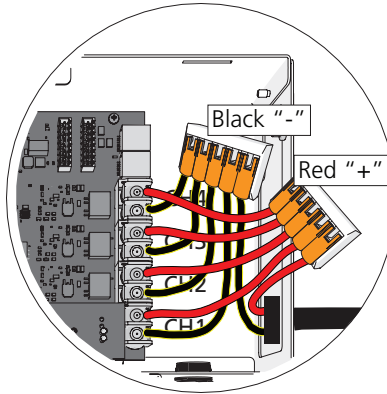

Wall-Mount D4 Driver 350

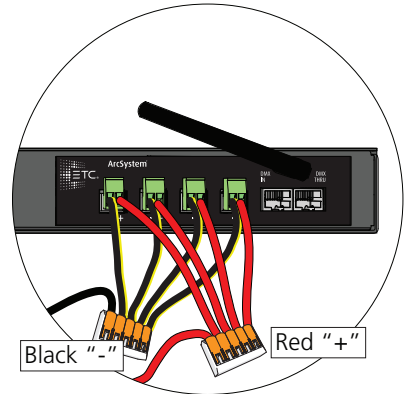

Rack-Mount D4 Driver 350



Note: Do not bridge three or four output channels into one output channel on a D4 Driver 700.

D4 Driver 150 Switch Settings for Four Output Channels Bridged into One

Switch Block (Output)	Switch Positions					
	1	2	3	4	5	6
S1 (LED 1)	Do not adjust from factory setting	ON	OFF	OFF	OFF	Do not adjust from factory setting
S2 (LED 2)		ON	OFF	OFF	OFF	
S3 (LED 3)		ON	OFF	OFF	OFF	
S4 (LED 4)		ON	OFF	OFF	OFF	

D4 Driver 350 Switch Settings for Four Output Channels Bridged into One

Switch Block (Output)	Switch Positions					
	1	2	3	4	5	6
S4 (CH 1)	Do not adjust from factory setting	ON	OFF	OFF	OFF	Do not adjust from factory setting
S3 (CH 2)		ON	OFF	OFF	OFF	
S2 (CH 3)		ON	OFF	OFF	OFF	
S1 (CH 4)		ON	OFF	OFF	OFF	

Output Channels Bridged in Pairs

Bridging pairs of output channels can be done as shown below for control on output channel 1 and output channel 2, or on any pair of output channels as long as the output channels that are electrically connected (bridged) have the same switch block settings. The illustrations and table below show output channel 1 and output channel 2 bridged to form bridged output channel 1 and output channel 3 and output channel 4 bridged to form bridged output channel 3.

Detail of output channels bridged in pairs.

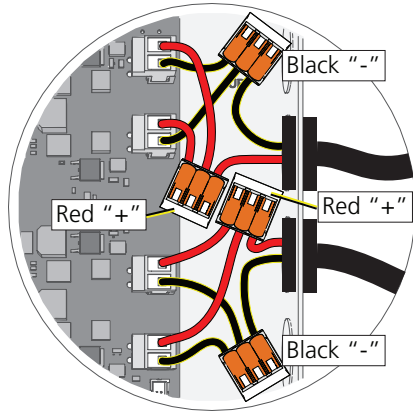

Wall-Mount D4 Driver 150

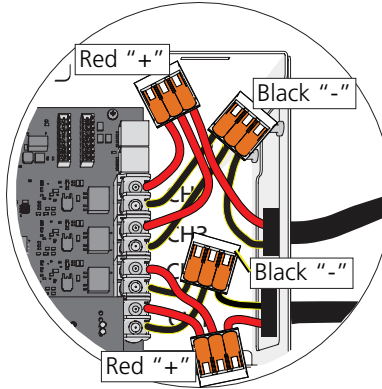

Wall-Mount D4 Driver 350/
Wall-Mount D4 Driver 700

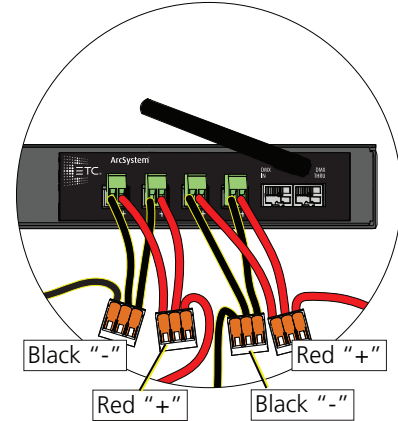

Rack-Mount D4 Driver 350/
Rack-Mount D4 Driver 700

D4 Driver 150 Switch Settings for Output Channels Bridged in Pairs

Switch Block (Output)	Switch Positions					
	1	2	3	4	5	6
S1 (LED 1)	Do not adjust from factory setting	ON	OFF	OFF	OFF	Do not adjust from factory setting
S2 (LED 2)		ON	OFF	OFF	OFF	
S3 (LED 3)		OFF	OFF	ON	OFF	
S4 (LED 4)		OFF	OFF	ON	OFF	

D4 Driver 350 and 700 Switch Settings for Output Channels Bridged in Pairs

Switch Block (Output)	Switch Positions					
	1	2	3	4	5	6
S4 (CH 1)	Do not adjust from factory setting	ON	OFF	OFF	OFF	Do not adjust from factory setting
S3 (CH 2)		ON	OFF	OFF	OFF	
S2 (CH 3)		OFF	OFF	ON	OFF	
S1 (CH 4)		OFF	OFF	ON	OFF	

Three Output Channels Bridged

Bridging three output channels can be done as shown below for control on output channel 1, or on any channel as long as the three output channels that are electrically connected (bridged) have the same switch block settings. The fourth output channel can be assigned to any of the three remaining channels. The table below shows output channels 1, 2, and 3 bridged to form bridged output channel 1 with output channel 4 at its factory setting.

Detail of three output channels bridged into one.

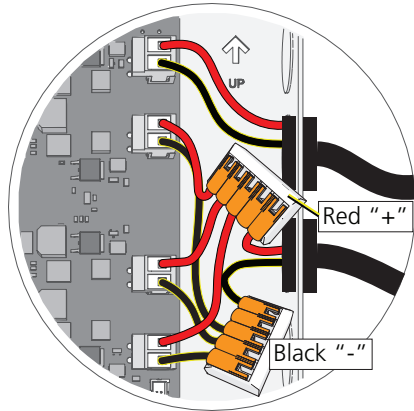

Wall-Mount D4 Driver 150

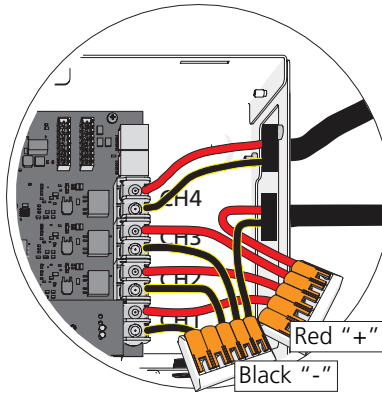

Wall-Mount D4 Driver 350

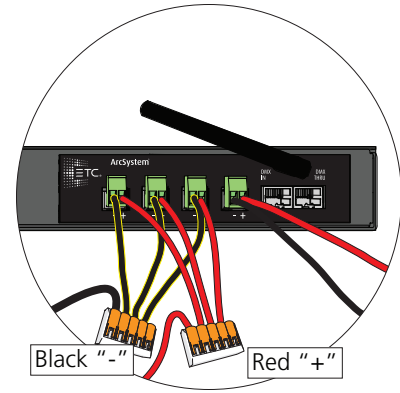

Rack-Mount D4 Driver 350



Note: Do not bridge three or four output channels into one output channel on a D4 Driver 700.

D4 Driver 150 Switch Settings for Three Output Channels Bridged into One

Switch Block (Output)	Switch Positions					
	1	2	3	4	5	6
S1 (LED 1)	Do not adjust from factory setting	ON	OFF	OFF	OFF	Do not adjust from factory setting
S2 (LED 2)		ON	OFF	OFF	OFF	
S3 (LED 3)		ON	OFF	OFF	OFF	
S4 (LED 4)		OFF	OFF	OFF	ON	

D4 Driver 350 Switch Settings for Three Output Channels Bridged into One

Switch Block (Output)	Switch Positions					
	1	2	3	4	5	6
S4 (CH 1)	Do not adjust from factory setting	ON	OFF	OFF	OFF	Do not adjust from factory setting
S3 (CH 2)		ON	OFF	OFF	OFF	
S2 (CH 3)		ON	OFF	OFF	OFF	
S1 (CH 4)		OFF	OFF	OFF	ON	

Bridging Procedure

The steps below describe how to bridge output channels on wall-mount and rack-mount D4 Driver models. Wall-mount D4 Driver models have four two-position screw-terminal connections located inside the enclosure. Rack-mount D4 Driver 350 and 700 models have four two-position screw-terminal plugs installed in the back of the enclosure. Outputs are labeled "LED 1", "LED 2", "LED 3" and "LED 4" (D4 Driver 150) or "CH 1", "CH 2", "CH 3", and "CH 4" (D4 Drivers 350 and 700). See the illustrated examples in [Example Bridge Configurations on page 52](#).

1. Turn off power to the D4 Driver or equipment rack.
2. Remove the cover of the driver to access the Output Channel Control Switches.
Wall-Mount D4 Driver:
 - Use a Phillips screwdriver to remove the two screws securing the lid to the enclosure. Set the cover and screws aside. You will reinstall them later.**Rack-Mount D4 Driver:**
 - Remove the rack-mount D4 Driver to access its cover.
 - Use a Phillips screwdriver to remove the four screws securing the D4 Driver cover. Set the cover and screws aside. You will reinstall them later.
3. Set switches 2–5 of switch blocks S1–S4 to the same output channel setting for each set of output channels that you want to bridge. See the explanation and examples in [Output Channel Control Switches on page 49](#).
4. **Rack-Mount D4 Driver:** Replace the cover on the rack-mount D4 Driver and reinstall the driver in the equipment rack.
5. Choose the WAGO connector with black wires from the bridging kit. The WAGO connector should have at least one more position than the number of channels to be bridged.
6. Bus the negative poles of the output channel connectors. Outputs are labeled "LED 1", "LED 2", "LED 3" and "LED 4" (D4 Driver 150) or "CH 1", "CH 2", "CH 3", and "CH 4" (D4 Drivers 350 and 700).
 - Terminate one black jumper wire to each negative terminal ("-") of the output channels to be bridged, securing each terminal screw onto the fork or wire. Tug gently to make sure the wires are secure.
7. Run positive and negative wires from the constant-voltage load to the driver or equipment rack.
8. Use a free position on the negative WAGO connector as the negative terminal of the new output channel. Terminate the negative wire from the constant-voltage load to the negative terminal.
 - Lift up the orange clip, insert the wire, and press the clip down onto the wire. Tug gently to make sure the wire is secure.
9. Remove any unused wires from the WAGO connector.
10. Repeat steps 5–9 to bus together positive ("+") terminals using the WAGO connector with red jumper wires.
11. Use a free position on the positive WAGO connector as the positive terminal of the new output channel. Terminate the positive wire from the constant-voltage load to the positive terminal.
 - Lift up the orange clip, insert the wire, and press the clip down onto the wire. Tug gently to make sure the wire is secure.
12. **Wall-Mount D4 Driver:** Reinstall the lid with the two screws removed in step 2.

Appendix B

Compliance

For current and complete compliance information, view the product datasheets at etconnect.com/ArcSystem. For complete product documentation, including compliance documentation, visit etconnect.com/products.



Note: *To comply with the requirements of CSA C22.2 No. 250.13, DMX/RDM networks must not have more than 32 device loads per daisy chain. This product is not self-terminating. You must terminate the last driver on the daisy chain with a 120 Ω resistor. To purchase an RJ45 terminator, please contact your ETC customer service representative and request part number N4086. For eight-pin DMX termination, you must terminate the last driver in line with a 120 Ω resistor (not provided) installed between terminals/pins 2 & 3 of the Thru output.*



Corporate Headquarters ■ Middleton, WI, USA | +1 608 831 4116
Global Offices ■ London, UK | Rome, IT | Holzkirchen, DE | Paris, FR | Hong Kong | Dubai, UAE | Singapore
New York, NY | Orlando, FL | Los Angeles, CA | Austin, TX
Web etcconnect.com | **Support** support.etcconnect.com | **Contact** etcconnect.com/contactETC
© 2023 Electronic Theatre Controls, Inc. | Trademark and patent info: etcconnect.com/ip
Product information and specifications subject to change. ETC intends this document to be provided in its entirety.
7490M2170 Rev F Released 2023-02