

READ AND SAVE THESE INSTRUCTIONS

**JEM™**

**AF-1 MKII™**

**JEM™**

**AF-2™**

# USER MANUAL



**Martin®**

# DIMENSIONS

All dimensions are in millimeters

## AF-1 MkII

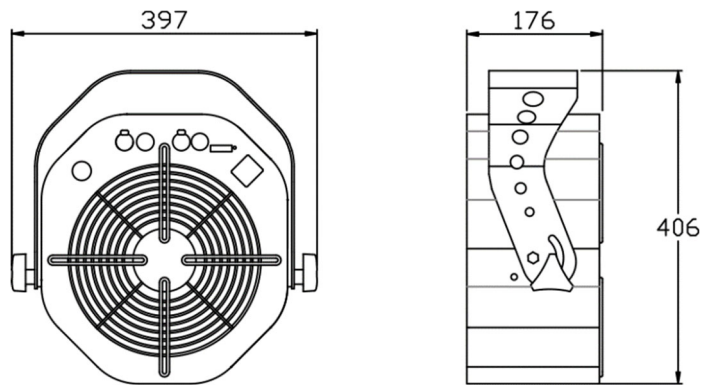

## AF-2

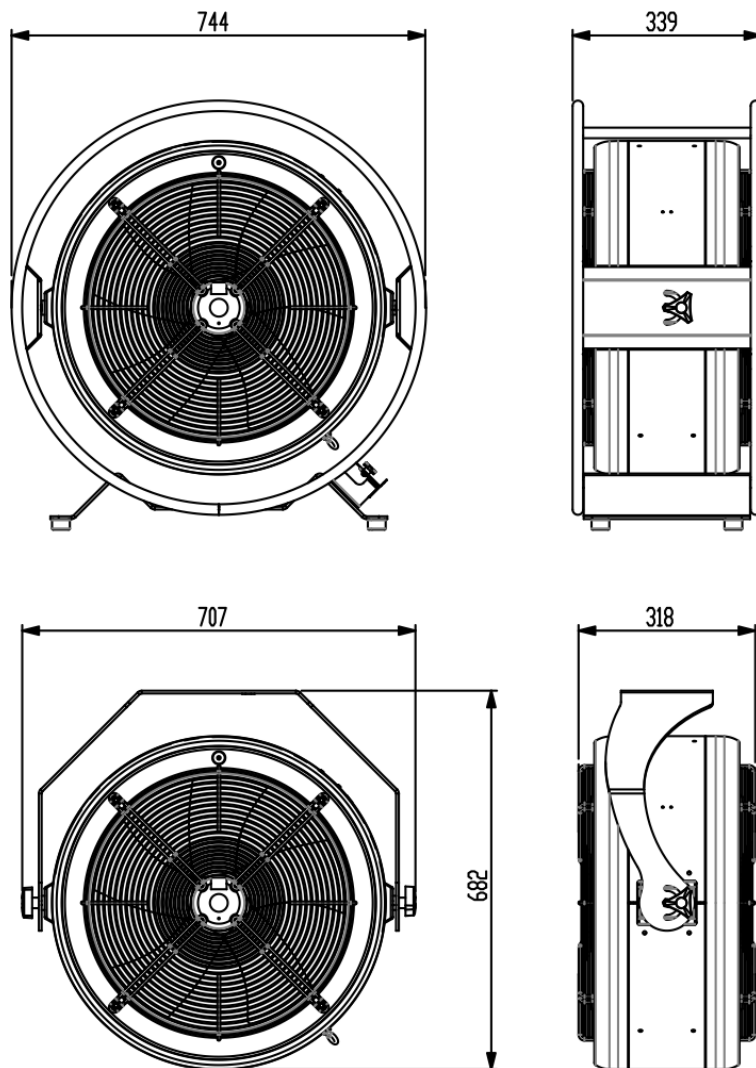

---

©2021 HARMAN PROFESSIONAL DENMARK ApS. All rights reserved. Features, specifications and appearance are subject to change without notice. HARMAN PROFESSIONAL DENMARK ApS and all affiliated companies disclaim liability for any injury, damage, direct or indirect loss, consequential or economic loss or any other loss occasioned by the use of, inability to use or reliance on the information contained in this document. Martin® and JEM™ are registered trademarks of HARMAN PROFESSIONAL DENMARK ApS registered in the United States and/or other countries.

HARMAN PROFESSIONAL DENMARK ApS, Olof Palmes Allé 44, 8200 Aarhus N, Denmark  
HARMAN PROFESSIONAL SOLUTIONS U.S., 8500 Balboa Blvd., Northridge CA 91329, USA

[www.martin.com](http://www.martin.com)

---

# CONTENTS

<b>Introduction .....</b>	<b>6</b>
Features .....	6
Safety information .....	7
Unpacking .....	8
<b>Installation .....</b>	<b>9</b>
AC power .....	9
Physical installation.....	10
<b>Installing control hardware .....</b>	<b>12</b>
Remote control installation.....	12
DMX installation .....	12
<b>Operation .....</b>	<b>16</b>
Using fans with smoke machines.....	16
Using fans with smoke ducting .....	16
Remote control operation.....	17
DMX control .....	21
<b>Service and maintenance .....</b>	<b>22</b>
Cleaning.....	22
Replacing the main fuse (EU models) .....	24
<b>Troubleshooting .....</b>	<b>25</b>
<b>AF-1 MkII™ specifications.....</b>	<b>26</b>
<b>AF-2™ specifications.....</b>	<b>28</b>

# Connections panels

## AF-1 MkII™

EU model

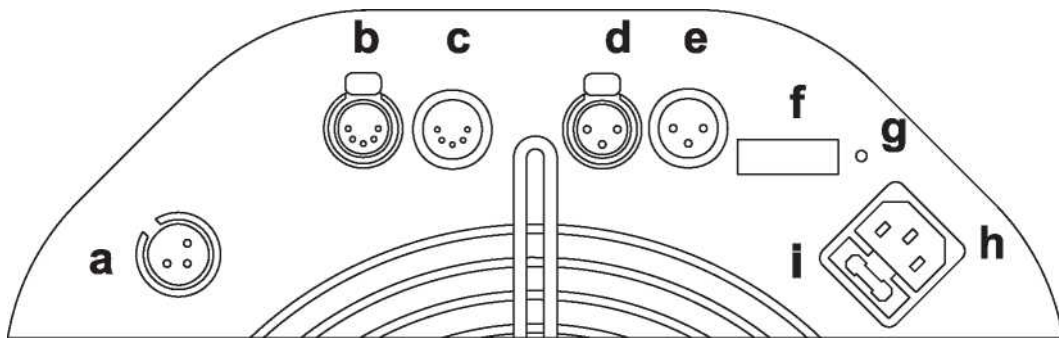

US model

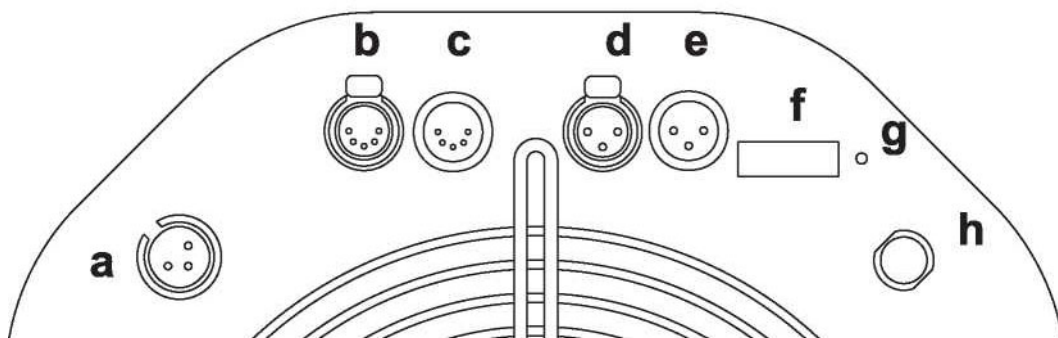

- a - Remote in
- b - DMX out (5-pin XLR)
- c - DMX in (5-pin XLR)
- d - DMX out (3-pin XLR)
- e - DMX in (3-pin XLR)

- f - DIP switch
- g - Data LED
- h - Power inlet
- i - Fuseholder (EU model only)

# AF-2™

## EU model

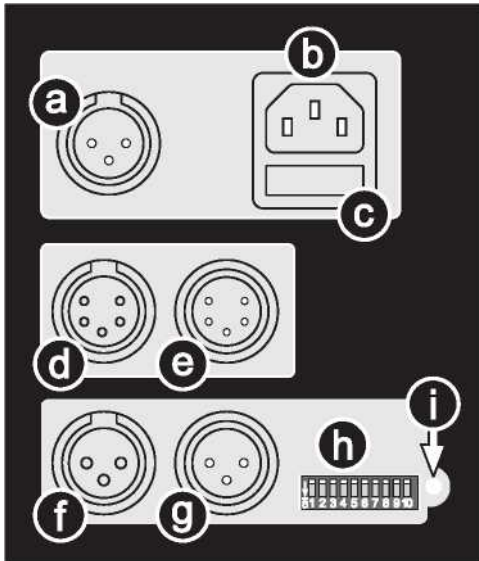

- a – Remote in
- b – Power inlet
- c – Main fuseholder
- d – DMX out (5-pin XLR)
- e – DMX in (5-pin XLR)
- f – DMX out (3-pin XLR)
- g – DMX in (3-pin XLR)
- h – DIP switch
- i – Data LED

## US model

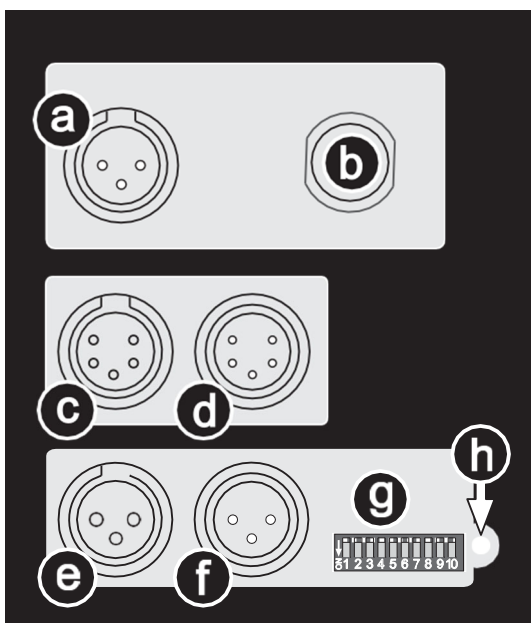

- a – Remote in
- b – Power inlet
- c – DMX out (5-pin XLR)
- d – DMX in (5-pin XLR)
- e – DMX out (3-pin XLR)
- f – DMX in (3-pin XLR)
- g – DIP switch
- h – Data LED

# INTRODUCTION

Thank you for selecting a Jem AF series fan.

The AF-1 MkII™ and AF-2™ fans are powerful machines designed for professional and semi-professional use in clubs, TV studios, theaters and touring contexts. They are suitable for a wide range of applications including smoke and haze dispersal, sending smoke through ducting, wind effects and cooling performers or equipment. When fans are used at high output in conjunction with a smoke machine at low output, a perfect haze effect can be produced.

Both fans have high quality sealed motors designed to withstand the high condensation levels associated with close proximity smoke

AF-1 MkII™ and AF-2™ fans can be controlled using the remote control unit supplied with each product or via DMX on a serial data link. They may be interfaced with all Martin and Jem smoke machines to allow simultaneous smoke and fan operation.

When used in combination with smoke machines, etc., DMX control allows atmospheric effects to be integrated in the light show directly from the lighting console. The remote control allows variable fan speed in continuous or timer operation. When using the built-in timer, operating periods and intervals between operating periods can be set independently.

AF-1 MkII™ and AF-2™ fans can be installed at any angle.

## Features

---

- DMX control.
- Remote control unit with instant or timer-controlled operation.
- Variable fan speed.
- Adjustable flying bracket with installation at any angle
- Can be flown or placed on a flat surface
- Rugged construction.
- Sealed high-quality maintenance-free fan motor offers high airflow, high resistance to condensation, ingress of dirt, smoke fluid, etc. and low noise.

# Safety information

---



**Warning!** *This product is not for household use. It presents risks of lethal or severe injury due to electric shock, falls and fast-moving blades.*



**Warning!** *To reduce the risk of fire, electric shock, or injury to persons, do not use replacement parts that have not been recommended by the manufacturer (e.g., parts made at home using a 3D printer).*

**To reduce the risk of fire or electric shock, do not use this fan with any solid-state speed control device.**

**Read this manual** before powering or installing the fan, follow the safety precautions listed below and observe all warnings in this manual and printed on the machine. Save this manual for future reference. If you have questions about how to operate the system safely, please visit [www.martin.com/en-US/support](http://www.martin.com/en-US/support) to find your local Martin service center.

Refer any service operation not described in this manual to a qualified technician.

## Preventing electric shocks

- Always ground (earth) the machine electrically.  
Use only a source of AC power that complies with local building and electrical codes, and that has both overload and ground-fault protection.
- Check the AC supply voltage is correct for use with the machine. The voltage setting is printed on the machine's serial label.
- Disconnect the machine from power before removing any components or servicing, and when not in use.
- Moisture can cause dangerous electrical faults. Do not aim fog output at electrical connections or devices.
- Do not expose this machine to wet conditions – the machine is not waterproof.
- Do not spill fluid over the machine. If fluid is spilled, disconnect the machine from power and clean with a damp cloth. If fluid is spilled onto electronic parts, contact your local Martin service center for assistance.
- Do not dismantle or attempt to repair a faulty machine. Refer all service to an authorized Martin service center.
- Do not operate the machine if the power cable or connector is damaged. A damaged cable or connector must be replaced with a new item, available from your local Martin service center.
- Do not operate the machine with damaged, deformed or missing parts.

## Preventing burns and fire

- Ensure that airflow around the machine is free and unobstructed.
- Do not operate the machine if the ambient temperature ( $T_a$ ) exceeds 55° C (131° F).

## Preventing injuries

- Never allow any object or part of your body to enter the path of the fan blades, and ensure that clothing, cables or other items cannot be sucked into the fan. Position the fan well out of reach of members of the public.
- Disconnect the fan from power before removing any cover or grill. Do not operate the fan unless all covers and grills are installed and securely fastened.
- Ensure that the supporting structure or surface can hold at least 10 times the weight of all installed devices.  
Use an approved means of secondary attachment such as a safety cable.
- Work from a stable platform and block access below the work area when installing, servicing or removing the machine.

## Unpacking

---

AF-1 MkII™ and AF-2™ fans are supplied with:

- Remote control unit with cable
- Power cable
- User manual
- Adjustable flying bracket

# INSTALLATION

This product must be installed by qualified personnel only.

## AC power

---

AF-1 MkII™ and AF-2™ fans are available in two models:

- US model: 115 V, 50/60 Hz (for use with 100-120 VAC, 60 Hz power supplies) with integral power cord
- EU model: 230 V, 50/60 Hz (for use with 220-240 VAC, 50 Hz power supplies) with separate power cable connected via an IEC socket



The product's voltage range is indicated on its serial number label. Do not operate the product at any other voltage.

**Warning!** *For protection from fire and electric shock, AF-1 MkII™ and AF-2™ fans must be grounded (earthed). The power supply must have overload and ground-fault protection.*

*Check that power cables are undamaged and rated for the current requirements of all connected devices before use.*

## Installing a mains plug on the power cable

On EU (230 V, 50/60 Hz) models, the power cable must be fitted with an earthed mains plug (grounding-type cord cap) that fits your power distribution system. Consult a qualified electrician if you have any doubts about proper installation.

Wire color (US)	Wire color (EU)	Pin	Symbol	Screw (US)
Green	Green-yellow	Ground (earth)	 or 	Green
White	Blue	Neutral	<b>N</b>	Silver
Black	Brown	Live	<b>L</b>	Yellow or brass

**Table 1: Mains plug connections**

Following the mains plug manufacturer's instructions, connect the power cable's green and yellow wire to ground (earth), blue wire to neutral and brown wire to live. Table 1 shows some pin identification schemes.

## Physical installation

---

AF-1 MkII™ and AF-2™ fans may be suspended from a suitable support such as a truss, placed on a horizontal surface or fastened to a surface using the bracket provided. Both fans can be installed at any angle.

The AF-2™ fan may be installed in a touring frame available as an accessory and either suspended from a suitable support such as a truss or placed on a horizontal surface resting on the touring frame's rubber feet.

**Warning!** *The slight vibration of the fan may cause fasteners to loosen. Check all fasteners regularly for tightness, especially when the machine is newly installed.*

*Position AF-1 MkII™ and AF-2™ fans well out of reach of the public.*

### Suspending from a support

**Warning!** *Block access below the work area and work from a stable platform when installing, servicing or removing the machine.*

*Use a secure secondary attachment that can hold at least 10 times the weight of the machine.*

Rigging clamps, omega brackets and fasteners are available as accessories from your local Martin service center. Any quarter-turn fasteners used must be turned a full 90° clockwise to lock them (see illustration on right).

1. Check that any structure used to support the machine can support at least 10 times the total weight of all installed fixtures, clamps, cables, auxiliary equipment, etc.

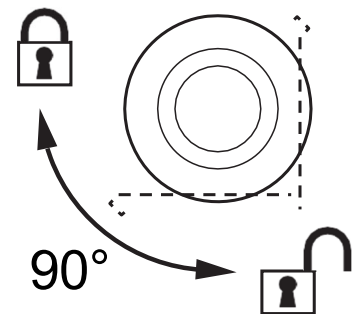

2. Check that all rigging clamps and fasteners are undamaged and can support at least 10 times the machine's weight.
  - **AF-1 MkII fan:** Bolt a rigging clamp to the machine's flying bracket using a grade 8.8 (minimum) M12 bolt and lock nut, or as recommended by the clamp manufacturer, through the 13 mm hole in the center of the mounting bracket.
  - **AF-2 fan:** Two rigging options exist. Either:
    - a) Bolt two rigging clamps to two Martin standard omega brackets (P/N 91602001) using grade 8.8 (minimum) M12 bolts and lock nuts, or as recommended by the clamp manufacturer. Fasten the two omega brackets to the flying bracket or touring frame. This option allows the fan to be flown in line with or at 90° to a truss. or:
    - b) Bolt one rigging clamp to one Martin 250-300 wide omega bracket (P/N 91602000). Fasten the wide omega bracket to the flying bracket or touring frame. This option allows the fan to be flown at any angle relative to the truss.

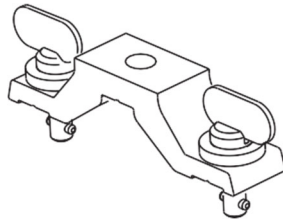

**Martin standard omega bracket: P/N 91602001**

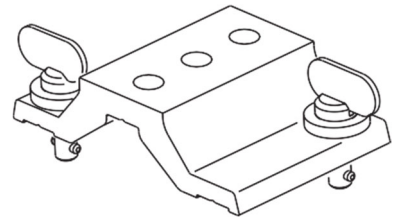

**Martin 250-300 wide omega bracket: P/N 91602000**

3. Clamp the fan to a truss or similar support.
4. Loop a safety wire that can hold at least 10 times the weight of the machine through/over the support and through the flying bracket or touring frame.
5. Loosen the swivel locks and tilt the fan to the desired angle. Turn the swivel locks clockwise to tighten. Check that fan, hardware and safety attachment are secure before applying power.

## Placing on a horizontal surface

If an AF-1 MkII or AF-2 fan is to be placed on a horizontal surface:

- Ensure that the surface is level, stable and capable of supporting at least ten times the weight of the machine.
- Secure the machine so that it cannot slide or fall, even if air pressure during full speed operation and vibration are present.
- Eliminate any risk of accidental contact.

# INSTALLING CONTROL HARDWARE

The AF-1 MkII™ and AF-2™ can be operated either using the Jem multifunction remote control unit supplied with each machine, or via DMX using a DMX control device and serial data link.

## Remote control installation

---

To connect the remote control unit:

1. Power the fan off.
2. Plug the XLR connector on the remote control cable into the REMOTE IN plug on the connections plate (see “*Connections panels*” on page 4).
3. Reapply power.

The AF-2 touring frame available as an accessory includes a docking station for the remote control unit (see illustration below). The remote control can be fastened in place using the two thumbscrews provided, and the remote cable wrapped around the brackets.

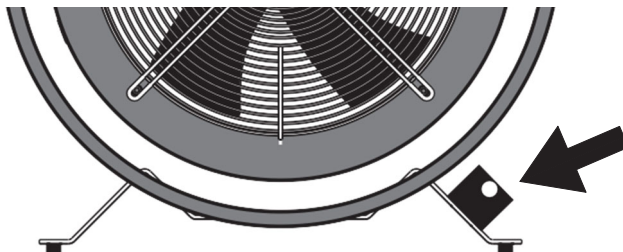

## DMX installation

---

Up to 32 devices can be controlled on one DMX data link. Devices must be ‘daisy-chained’ in one continuous line without branches. More devices can be added and the link can be branched using an optically isolated splitter/amplifier such as the Martin RS-485 Opto-Splitter (P/N 90758060).

### DMX cable connection

A reliable DMX data connection requires suitable cable. Standard microphone cable cannot transmit DMX data reliably over long runs. For

best results, use shielded cable with at least one twisted pair specifically designed for RS-485 applications. Your local Martin service center can supply suitable high quality cable in various lengths.

AF-1 MkII™ and AF-2™ both connect to a serial DMX data link using either their 3-pin or their 5-pin XLR DMX In and Out connectors. DMX connectors are wired with pin 1 to ground, pin 2 to signal - (cold), and pin 3 to signal + (hot). This is the standard pin assignment for DMX devices.

To connect the DMX data link:

1. Power all devices off.
2. Connect a data cable from the controller's DMX data output to the first device's DMX input
3. Connect the DMX output of this device to the DMX input of the next device.
4. Continue connecting up to a total of 32 devices in one single line, output to input.
5. Terminate the link by inserting a male termination plug (available from your local Martin service center: P/N 91613017) into the data output of the last device. A termination plug is simply an XLR connector with a 120 Ohm, 0.25 W resistor soldered across pins 2 and 3.

## Specifying DMX control channels

AF-1 MkII™ and AF-2™ use a single DMX control channel to receive instructions from the controller. This control channel is the DMX address.

To control machines individually, each must have its own unique DMX address. To control identical machines as a group, they can all be given the same DMX address. They will then receive the same instructions and should behave identically. Setting up identical fixtures with the same DMX address can also be a good tool for troubleshooting unexpected behavior.

The DMX address on AF-1 MkII™ and AF-2™ fans can be set to any channel from 1 to 511 using DIP-switch pins 1 - 9. To set the DMX address:

1. Decide on an available DMX address for each machine.
2. Power the controller and all devices off.
3. For each device, set the DMX address by setting DIP-switch pins 1 through 9 to the ON (1) or OFF (0) position as listed in the table on the next page. As an example, channel 101 is highlighted in the table.

### **DMX address DIP-switch settings**

To use Table 2, first find the DMX address in the main block in the table. Then read the settings for pins 1 - 5 to the left and read the settings for pins 6 - 9 above the address. "0" means OFF and "1" means ON.

For example, to set the DMX address to 101, you need to set DIP-switch pins 1, 3, 6 and 7 to ON, as highlighted in the table.

DIP switch pins setting 0 = OFF 1 = ON					#9	0	0	0	0	0	0	0	0	1	1	1	1	1	1	1	1
					#8	0	0	0	0	1	1	1	1	0	0	0	0	1	1	1	1
					#7	0	0	1	1	0	0	1	1	0	0	1	1	0	0	1	1
					#6	0	1	0	1	0	1	0	1	0	1	0	1	0	1	0	1
#1	#2	#3	#4	#5																	
0	0	0	0	0		32	64	96	128	160	192	224	256	288	320	352	384	416	448	480	
1	0	0	0	0	1	33	65	97	129	161	193	225	257	289	321	353	385	417	449	481	
0	1	0	0	0	2	34	66	98	130	162	194	226	258	290	322	354	386	418	450	482	
1	1	0	0	0	3	35	67	99	131	163	195	227	259	291	323	355	387	419	451	483	
0	0	1	0	0	4	36	68	100	132	164	196	228	260	292	324	356	388	420	452	484	
1	0	1	0	0	5	37	69	101	133	165	197	229	261	293	325	357	389	421	453	485	
0	1	1	0	0	6	38	70	102	134	166	198	230	262	294	326	358	390	422	454	486	
1	1	1	0	0	7	39	71	103	135	167	199	231	263	295	327	359	391	423	455	487	
0	0	0	1	0	8	40	72	104	136	168	200	232	264	296	328	360	392	424	456	488	
1	0	0	1	0	9	41	73	105	137	169	201	233	265	297	329	361	393	425	457	489	
0	1	0	1	0	10	42	74	106	138	170	202	234	266	298	330	362	394	426	458	490	
1	1	0	1	0	11	43	75	107	139	171	203	235	267	299	331	363	395	427	459	491	
0	0	1	1	0	12	44	76	108	140	172	204	236	268	300	332	364	396	428	460	492	
1	0	1	1	0	13	45	77	109	141	173	205	237	269	301	333	365	397	429	461	493	
0	1	1	1	0	14	46	78	110	142	174	206	238	270	302	334	366	398	430	462	494	
1	1	1	1	0	15	47	79	111	143	175	207	239	271	303	335	367	399	431	463	495	
0	0	0	0	1	16	48	80	112	144	176	208	240	272	304	336	368	400	432	464	496	
1	0	0	0	1	17	49	81	113	145	177	209	241	273	305	337	369	401	433	465	497	
0	1	0	0	1	18	50	82	114	146	178	210	242	274	306	338	370	402	434	466	498	
1	1	0	0	1	19	51	83	115	147	179	211	243	275	307	339	371	403	435	467	499	
0	0	1	0	1	20	52	84	116	148	180	212	244	276	308	340	372	404	436	468	500	
1	0	1	0	1	21	53	85	117	149	181	213	245	277	309	341	373	405	437	469	501	
0	1	1	0	1	22	54	86	118	150	182	214	246	278	310	342	374	406	438	470	502	
1	1	1	0	1	23	55	87	119	151	183	215	247	279	311	343	375	407	439	471	503	
0	0	0	1	1	24	56	88	120	152	184	216	248	280	312	344	376	408	440	472	504	
1	0	0	1	1	25	57	89	121	153	185	217	249	281	313	345	377	409	441	473	505	
0	1	0	1	1	26	58	90	122	154	186	218	250	282	314	346	378	410	442	474	506	
1	1	0	1	1	27	59	91	123	155	187	219	251	283	315	347	379	411	443	475	507	
0	0	1	1	1	28	60	92	124	156	188	220	252	284	316	348	380	412	444	476	508	
1	0	1	1	1	29	61	93	125	157	189	221	253	285	317	349	381	413	445	477	509	
0	1	1	1	1	30	62	94	126	158	190	222	254	286	318	350	382	414	446	478	510	
1	1	1	1	1	31	63	95	127	159	191	223	255	287	319	351	383	415	447	479	511	

**Table 2: DMX address DIP-switch settings**

### DIP-Switch 10 test function

DIP-switch 10 allows testing without a remote control or DMX signal. If you switch it to the ON (1) position, the fan runs at full output for 2 seconds.

# OPERATION

Before powering on, check that the fan is correctly and safely installed.

## Using fans with smoke machines

---

When using a fan in combination with a smoke machine, fog machine or hazer, place the fan behind the machine, as illustrated on the right. Do not place the fan in front of the machine and direct the output from the machine into the fan, as this will cause undesirable moisture and residue build-up. The fan blades will also degrade the quality of the smoke.

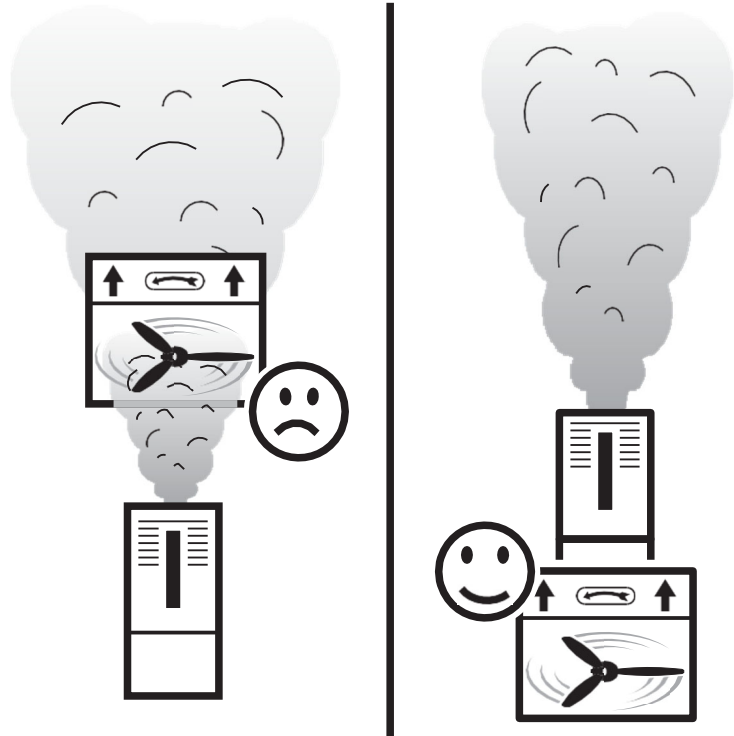

## Using fans with smoke ducting

---

For best results and easy directional control, connect fans to smoke ducting using a Y-shaped arrangement, placing the fan on one arm of the Y and the smoke machine on the other.

# Remote control operation

---

## AF-1 MkII™ remote control

### AF-1 Multifunction remote overview

- a LEVEL/ TIMER control
- b RUN/ TIMER ENGAGE button
- c TIMER OFF LED
- d TIMER ON LED
- e TIMER SET button

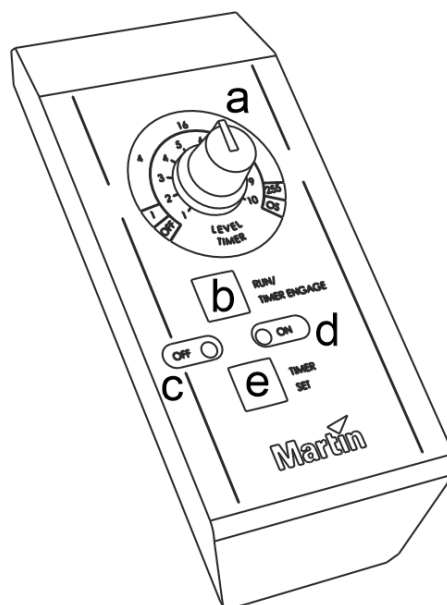

The AF-1 MkII™ remote offers the following control options:

- Continuous operation with fan speed adjustment
- Timer operation: timed fan bursts repeated at timed intervals
- "One shot" operation: single timed fan bursts that you trigger at will

### Continuous operation

To set up continuous operation:

1. Turn the LEVEL/ TIMER control to OFF
2. Press RUN/ TIMER ENGAGE once for less than one second. The fan will run continuously until this button is pressed again.
3. Once you have started continuous operation, adjust the fan speed level using the LEVEL/ TIMER control.

The green LEVEL/ TIMER LED lights in continuous operation.

### Timer operation

The automatic timer sets the AF-1 MkII™ to produce timed fan bursts at regular intervals. You need to set two times: the run/on time during which

the fan will run, and the wait/off time during which the fan will switch to idle. To set up timer operation:

1. Press TIMER SET. The ON LED will flash. You are now setting the On/Run time.
2. Turn the LEVEL / TIMER control to the required "run" time, as shown on the scale (OFF - 255 seconds).
3. Press TIMER SET once. The ON LED will light constantly and the OFF LED will flash. You are now setting the Off/Wait time.
4. Turn the LEVEL / TIMER control to the required "wait" time (OFF - 255 seconds).
5. Press TIMER SET once more. Both ON/OFF LEDs will light to show that the timer is programmed.

The run and wait times are now stored and will be remembered even after the unit has been powered off.

To start the timer using the times you have set, press RUN / TIMER ENGAGE briefly. To turn off the timer, press RUN / TIMER ENGAGE briefly again. When the timer is engaged, the ON LED lights during the On/Run time and the OFF LED lights during the Off/Wait time.

Additional functions:

- If you only want to change the Off/Wait time, leaving the On/Run time unchanged, press TIMER SET twice. This will take you directly to setting the Off time without changing the On time.
- To find out what the current time settings are, press TIMER SET then rotate the LEVEL / TIMER control slowly until the "ON" LED begins to flash very rapidly. The control is now set to the current run/on time. Press TIMER SET once and rotate the control slowly again until the "OFF" LED begins to flash very rapidly. The control is now set to the current wait/off time. Press TIMER SET again to return to normal operation.

### **"One-shot" operation**

"One shot" operation lets you run a fixed-time fan burst at will by pressing the RUN button. To set up "one-shot" operation:

1. Press TIMER SET. The ON LED will flash. You are now setting the On/Run time.
2. Turn the LEVEL / TIMER control to the required "run" time as shown on the scale (OFF - 255 seconds).
3. Press TIMER SET once. The ON LED will light constantly and the OFF LED will flash.
4. Turn the LEVEL / TIMER control fully right to "OS" ("One Shot").

5. Press TIMER SET once more.

The timer is now programmed to one-shot mode and this will be remembered even after the unit has been powered off.

To produce a timed fan burst, press RUN briefly. To stop the timed burst early, press RUN briefly again.

# AF-2™ remote control

## AF-2 Multifunction remote overview

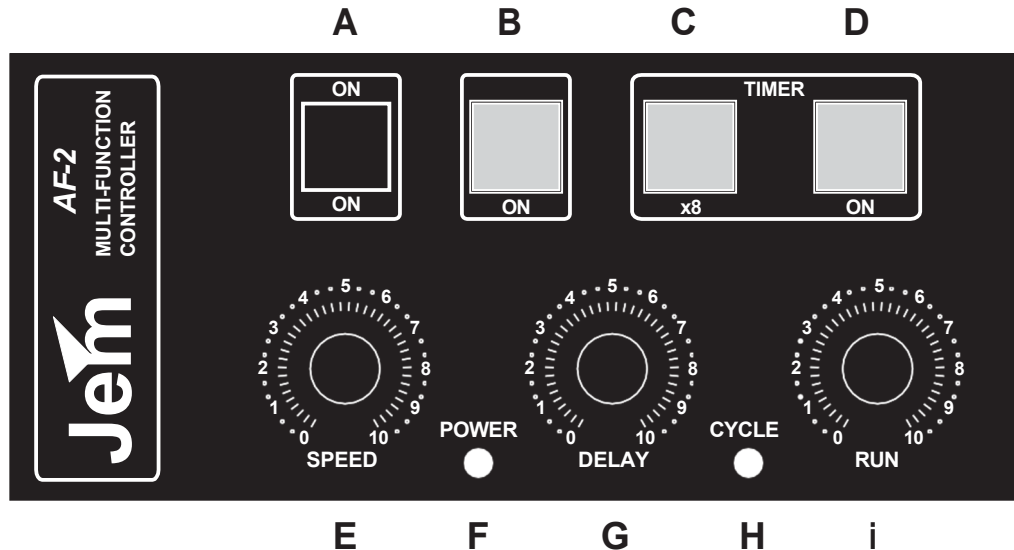

- A INSTANT FAN OPERATION BUTTON** – Press to run the fan at the speed set on the fan speed control.
- B STANDBY** – Puts the fan into standby mode. Must be set to ON to operate in any mode.
- C TIMER VALUE BUTTON** – When timer is active, adjusts timer values by a factor of 8 (i.e. a 5 second run time becomes 40 seconds and a 10 second delay time becomes 1 minute 20 seconds).
- D TIMER ENGAGE** – Engages the timer to run the fan according to the timer settings.
- E SPEED** – Sets fan speed from minimum to maximum.
- F POWER LED** – Lights when power is on.
- G DELAY TIME CONTROL** – Sets intervals between operating periods during timer-controlled operation.
- H CYCLE LED** – Lights during timer-controlled operation.
- I RUN TIME CONTROL** – Sets duration of operating periods during timer-controlled operation.

The multifunction remote control unit supplied with the AF-2™ allows instant or timer-controlled fan operation and airflow control. The unit also gives feedback on the status of the machine.

To set timer operation using the remote control:

1. Set the desired amount of airflow using the SPEED control
2. Set wait/off time intervals between operating periods by setting the DELAY control to between 1 and 9.
3. Set duration of operating periods by setting the RUN control to between 1 and 9.
4. Set the STANDBY button to ON
5. Set the TIMER ON button to ON.

The CYCLE LED lights when the timer function is active.

To extend timer settings, press the X8 button. This will multiply both RUN and DELAY times by 8.

## DMX control

---

Fan speed on the AF-1 MkII™ and AF-2™ can be controlled using a DMX controller.

### DMX controller operation

When a fan is powered on, the Data LED next to the DIP-switch will light when a valid DMX signal is received.

Increase the value on the machine's DMX control channel to increase fan speed as shown below:

#### DMX control channel levels

Level	Percentage	Effect
0-27	0-10%	Fan speed zero.
28-255	11-100%	1 - 100% fan speed.

# SERVICE AND MAINTENANCE

Any service procedure not described here should be referred to a qualified technician.

**Warning!** *Disconnect the fan from power before removing any grills or covers.*

## Cleaning

---

Clean the outside of the fan with a damp cloth only. Do not use solvents.

Periodic cleaning of the fan blades and grills is necessary to maintain peak performance. Cleaning intervals will depend on the operating environment. Inspect the fan regularly for dust and smoke residue buildup, and clean as soon as there is significant dirt buildup on fan blades or at the first signs that airflow through grills may be restricted.

Use a soft brush and vacuum to clean grills and fan blades.

### AF-1 MkII cleaning access

1. Disconnect the fan from power.
2. Remove the four cross-head screws (arrowed) from the grill and lift the grill/motor assembly clear of the housing. The motor cable will remain attached to the motor and the housing. Avoid straining the cable.
3. After cleaning, replace the grill and screws, ensuring that screws are securely tightened.

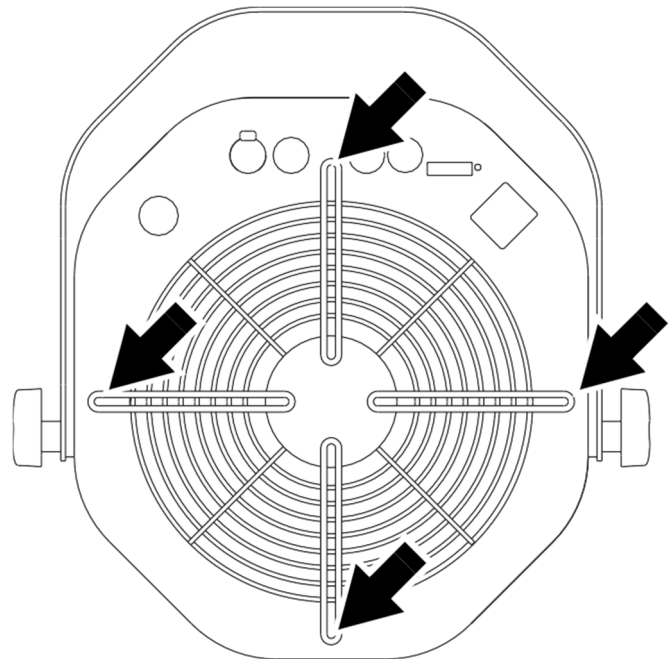

## AF-2 cleaning access

1. Disconnect the fan from power.

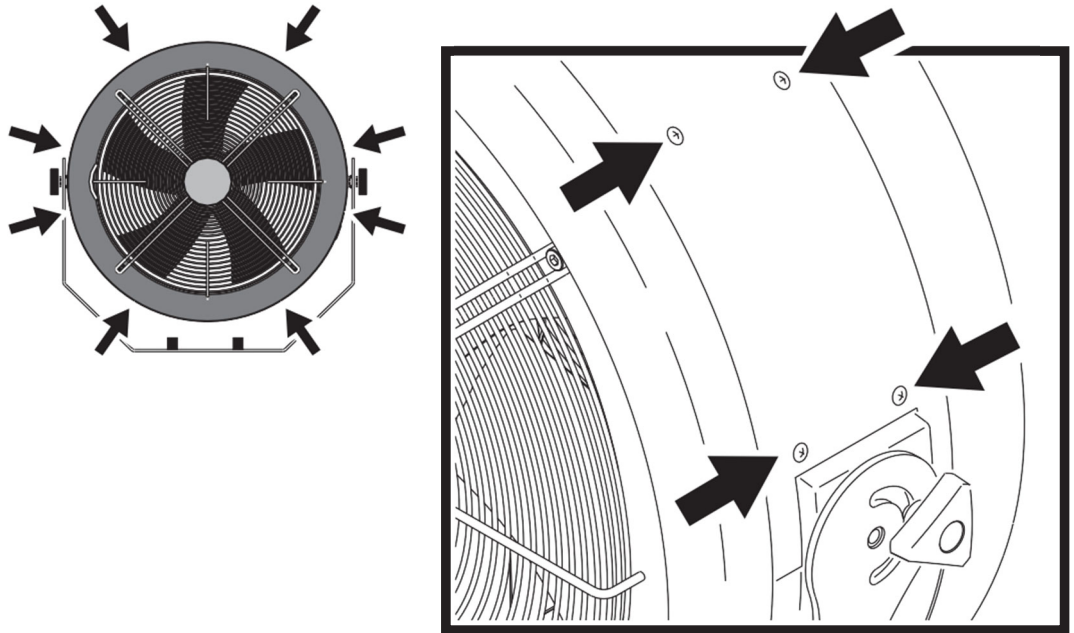

2. Remove the 16 cross-head screws from the covers (see illustration above), and remove the covers.
3. Reaching into the fan housing for access to the locking nuts, remove the four 6mm Allen screws holding the front grill (see illustration on right), collecting all washers and grommets for re-use.

Note: the front grill is on the opposite side from the fan motor. It should be possible to clean the machine without removing the rear grill that holds the fan motor.

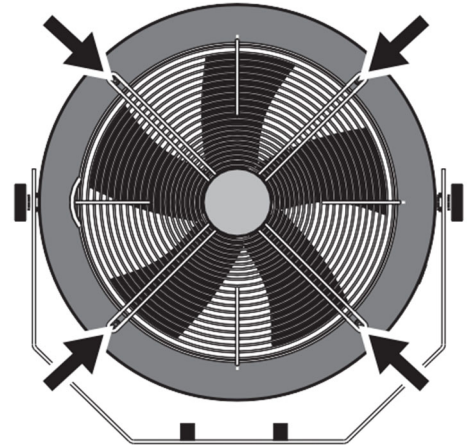

4. After cleaning, replace the screws and front grill. Reassemble exactly as shown in the next illustration, making sure that the rubber

grommets (A) are seated in the fan housing (B). If this assembly sequence is not respected, the AF-2 will be excessively noisy.

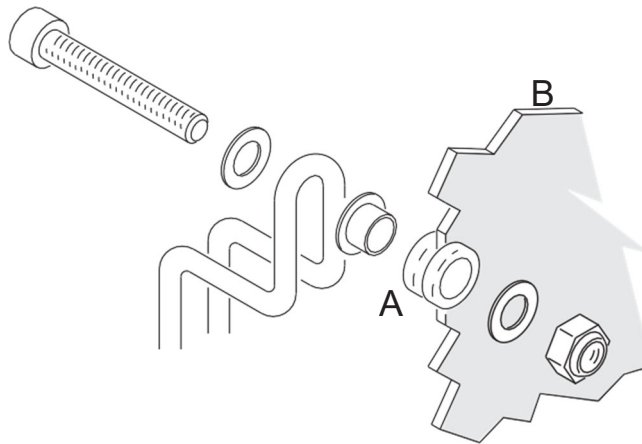

## Replacing the main fuse (EU models)

---

EU models have a main fuse that can be changed by the user.

On US models the main fuse is internal. If you suspect that the main fuse has blown, please contact your local Martin service center for assistance. An indication that the main fuse may have blown is that, when power is applied:

- the Data LED does not light when a DMX signal is present, or
- the ON LED (AF-1 MkII™) or Power LED on the remote (AF-2™) does not light when a remote control is connected.

The main fuse can be replaced by the user if necessary. Never bypass the fuse or replace it with one of another size or rating.

To replace the main fuse:

1. Disconnect the power cable from the fan.
2. Use a screwdriver to lever the fuseholder out of the power inlet socket (see illustration).
3. Replace the fuse with one of the same rating and type. Fuse details are given on the serial number label and in the Specifications sections of this manual.
4. Replace the fuseholder and reconnect to power.

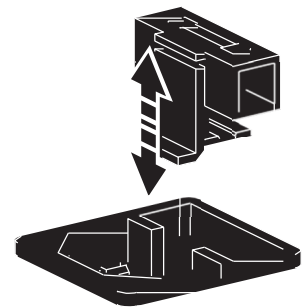

If the fuse blows repeatedly, disconnect the machine from power and from control equipment and contact your local Martin service center for assistance.

# TROUBLESHOOTING

<b>Problem</b>	<b>Probable cause(s)</b>	<b>Suggested remedy</b>
No light from status LEDs on remote control or fan	No power	Check power supply and connections
	Remote control not set to Standby (AF-2™ only)	Press Standby button
	Remote control not connected	Check connections
	RUN / TIMER button not pressed (AF-1 MkII™ only)	Press button.
	Fuse blown	Replace fuse with one of same type and rating. If fuse blows repeatedly, consult your local Martin service center.
Power is applied, but no fan action using DMX	Incorrect DMX address	Check DIP-switch settings
	No DMX termination	Fit termination plug to last device on DMX link
Excessively noisy operation	Grill loose	Check and tighten grill retaining screws
	AF-2: Incorrectly assembled grill mounting hardware	Check, and if necessary reassemble (see “AF-2 <i>cleaning access</i> ” on page 23)
Reduced airflow	Grills and/or fan blades dirty	Check and clean
	Low supply voltage	Check AC supply

# AF-1 MkII™ SPECIFICATIONS

## Physical (flying bracket installed)

Width .....	380 mm (15.0 in.)
Height .....	410.5 mm (16.2 in.)
Depth .....	180 mm (7.1 in.)
Weight .....	8.5 kg (18.7 lbs.)

## Construction

Housing .....	Steel
Finish .....	Black

## Performance

Fan speed. ....	200 - 2500 rpm approx.
Max. airflow .....	1815 m <sup>3</sup> per hour (64 cu.ft.per hour)
Operation time.....	Continuous
Noise level (max.) .....	70 dBA

## Control and programming

Control options .....	Remote control unit (supplied), DMX, test switch
Remote control functions .....	Instant or timer-controlled output, ..... 0-100% output level adjustment
Delay time .....	2 - 255 seconds
Run time .....	2 - 255 seconds
Max. length of remote cable .....	50 metres (3 metres supplied)
DMX channels.....	1
DMX addressing.....	DIP-switch
DMX compliance .....	USITT DMX-512A

## Installation

Orientation .....	Any
Minimum clearance around machine.....	0.1 m (4 in.)

## Connections

Remote control.....	3-pin locking XLR
DMX .....	3-pin and 5-pin locking XLR
AC power .....	IEC power inlet (EU model), integral power cord (US model)

## Electrical

### *US model*

AC power .....	110-120 V nominal, 50/60 Hz
Main fuse (not user-changeable) .....	5 AT (slow blow)

### *EU model*

AC power .....	220-240 V nominal, 50/60 Hz
Main fuse.....	3.15 AT (slow blow)

## Typical Power and Current

US model at 115 V, 60 Hz .....	175 W, 1.48 A
EU model at 230 V, 50 Hz .....	120 W, 0.53 A

*Measurements made at nominal voltage. Allow for a deviation of +/- 10%.*

## Thermal

Minimum ambient temperature ( $T_a$ min.) .....	0° C (32° F)
Maximum ambient temperature ( $T_a$ max.) .....	55° C (131° F)

## Approvals



EU Safety .....	EN 60 335-1
EU EMC .....	EN 61000 6-3, EN 62233
EU Immunity.....	EN 61000-6-1
US Safety .....	UL 507
Canadian Safety .....	CSA C22.2 No.113
Australia/NZ (pending) .....	RCM
United Kingdom.....	UKCA

## Included items

Analog remote control with 3 m (9.8 ft) cable  
Adjustable flying bracket  
User manual

### **US model**

3 m (9.8 ft) integral power cable 18AWG  
with US cord cap (UL approved)..... P/N 11501502

### **EU model**

1.5 m (4.9 ft) IEC power cable 3 x 1.0mm<sup>2</sup> without mains plug ... P/N 11501012

## Accessories

G-clamp .....	P/N 91602003
Half-coupler clamp .....	P/N 91602005
DMX termination plug (end of link), XLR male .....	P/N 91613017

## Ordering information

Jem AF-1 MkII™ DMX Fan, US model, 115 V, 50/60 Hz.....	P/N 92615110
Jem AF-1 MkII™ DMX Fan, EU model, 230 V, 50/60 Hz.....	P/N 92615010

*Specifications subject to change without notice. For latest specifications and product information see [www.martin.com](http://www.martin.com)*

# AF-2™ SPECIFICATIONS

## Physical

Dimensions (L x W x H).....	600 x 310 x 600 mm
.....	(23.7 x 12.2 x 23.7 in.)
Dimensions, flying bracket installed (L x W X H) .....	700 x 310 x 680 mm
.....	(27.6 x 12.2 x 26.8 in.)
Dimensions, touring frame installed (L x W x H).....	750 x 335 x 770 mm
.....	(29.6 x 13.2 x 30.4 in.)
Weight .....	15.7 kg (34.7 lb.)
Weight including flying bracket .....	17.5 kg (38.6 lb.)
Weight including touring frame .....	21.4 kg (47.2 lb.)

## Construction

Housing .....	Aluminum
Finish.....	Black

## Performance

Fan speed. . . . .	0 - 1400 rpm @ 50 Hz
Max. airflow .....	5700 m <sup>3</sup> per hour (200 cu.ft. per hour)
Operation time.....	Continuous
Noise level (max.) .....	73 dBA

## Control and programming

Control options .....	Remote control unit (supplied), DMX, test switch
Remote control functions .....	Instant or timer-controlled output, ..... 0-100% output level adjustment
Delay time .....	2 - 20 seconds
Run time .....	2 - 20 seconds
Max. length of remote cable .....	50 metres (5 metres supplied)
DMX channels.....	1
DMX addressing.....	DIP-switch
DMX compliance . . . . .	USITT DMX-512-A

## Installation

Orientation .....	any
Minimum clearance around machine.....	0.1 m (4 in.)

## Connections

Remote control.....	3-pin locking XLR
DMX .....	3-pin and 5-pin locking XLR
AC power .....	IEC power inlet (EU model), integral power cord (US model)

## Electrical

### US model

AC power ..... 110-120 V nominal, 50/60 Hz  
Main fuse (not user-changeable).....6.3 AT (slow blow)

### EU model

AC power ..... 220-240 V nominal, 50/60 Hz  
Main fuse .....5 AT (slow blow)

## Typical power and current

US model at 115 V, 60 Hz ..... 350 W, 3.3 A  
EU model at 230 V, 50 Hz..... 245 W, 1.2 A  
*Measurements made at nominal voltage. Allow for a deviation of +/- 10%.*

## Thermal

Minimum ambient temperature ( $T_a$  min.) ..... 0° C (32° F)  
Maximum ambient temperature ( $T_a$  max.) ..... 55° C (131° F)

## Approvals



EU Safety ..... EN 60 335-1  
EU EMC ..... EN 61000 6-3, EN 62233  
EU Immunity..... EN 61000-6-1  
US Safety ..... UL 507  
Canadian Safety . . . . . CSA C22.2 No.113  
Australia/NZ (pending) ..... RCM  
United Kingdom..... UKCA

## Included items

Jem multifunction remote control with 5 m (16.4 ft) cable and XLR connector  
Adjustable flying bracket  
User manual

### US model

3 m (9.8 ft) integral power cable 18AWG  
with US cord cap (UL approved).....P/N 11501502

### EU model

1.5 m (4.9 ft) IEC power cable 3 x 1.0mm<sup>2</sup> without mains plug.....P/N 11501012

## Accessories

Touring frame, AF-2..... P/N 92620006  
Wide omega bracket 250-300 with 4 x quarter-turn fasteners ..... P/N 91602000  
Standard omega bracket with 2 x quarter-turn fasteners ..... P/N 91602001  
G-clamp..... P/N 91602003  
Half-coupler clamp ..... P/N 91602005  
DMX termination plug (end of link), XLR male ..... P/N 91613017

## Ordering information

Jem AF-2™ DMX Fan, US model, 115 V, 50/60 Hz ..... P/N 92615400  
Jem AF-2™ DMX Fan, EU model, 230 V, 50/60 Hz ..... P/N 92615300

*Specifications subject to change without notice. For latest specifications and product information see [www.martin.com](http://www.martin.com)*



**Disposing of this product**

Martin products are supplied in compliance with Directive 2012/19/EC of the European Parliament and of the Council of the European Union on WEEE (Waste Electrical and Electronic Equipment), where applicable. Help preserve the environment! Ensure that this product is recycled at the end of its life. Your supplier can give details of local arrangements for the disposal of Martin products

